

RAIDERS OF THE NORTH SEA—Great R.N.A.S. Adventure

AIR ^{7^D} STORIES



THE BALLOON-BUSTER |||

BY PHILIP ARNALL

SKY GUNS OF TO-DAY

Secrets of the Formidable Weapons used in Air Fighting

APRIL
EARLY "BIRDMEN"

BY MAJOR L. S. METFORD

10 MINUTES TO WAIT

before
going
on the
set'—
says



ADELE DIXON—'so

Mine's a Minor!

In taste, quality and packing the equal
of much dearer cigarettes, but not
quite so large; big enough, however,
to last the full 10 minutes.

PLAIN, CORK OR
'IVORY'-TIPPED

De Reszke MINORS

In tins : 30 for 1/- * 60 for 2/- * In boxes : 15 for 6/- * 30 for 1/-

Issued by Godfrey Phillips Ltd

FOR THAT LEISURED ¾ HOUR — DE RESZKE MAJORS, 20 for 1/-

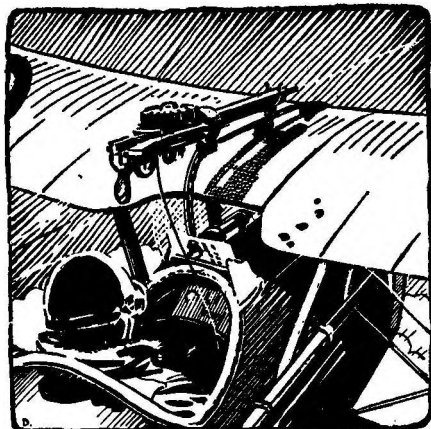

AIR STORIES

FLYING THRILLS AND
AERIAL ADVENTURE

APRIL, 1937.
Vol. 4. No. 4.

7d. per copy
9s. a Year

LONG COMPLETE R.N.A.S. ADVENTURE		PAGE
RAIDERS OF THE NORTH SEA	H. C. Parsons	286
Up from an East Coast Air Station rose the Strangest Patrol of the War bound across the North Sea on a Dangerous Game of Raiding the Raiders		
TWO GREAT FACT ARTICLES		
SKY GUNS OF TO-DAY	"Armourer Sergeant"	317
Secrets of the Formidable Weapons of Modern Air Fighting		
No. 25 SQUADRON, R.F.C.	W. Maclanachan	339
The Stirring War Story of One of the Famous R.F.C. Squadrons		
THRILLING MODERN AIR ADVENTURE		
HAWK OF ALLAH	Leslie Thompson	308
In a Fighter snatched from the R.A.F., the Hawk of Allah launched the Raid that was to set the Frontier ablaze with Revolt		
THREE DRAMATIC AIR WAR STORIES		
THE BALLOON-BUSTER	Philip Arnall	345
A Fokker Triplane and a British Balloon was a Curious "Bag" for any One Pilot to Collect		
ESCAPE	F. I. Hurley	331
An Unusual Story of a Prisoner-of-War to Whom no Price was too Great for the Chance of Escape		
EARLY "BIRDMEN"	Major L. S. Metford	356
The General Thought Nothing Impossible for his "Birdmen" and Lieut. James Stirling Suffered a Lot to Prove he was Right		
SPECIAL AIR FEATURES		
AN ACE OF TWO-SEATERS	By A. H. Pritchard	327
FOREIGN FIGHTERS	By A. C. Leverington	306
MODEL SECTION (The Vickers Bullet)	By J. H. Stevens	371
AIR BOOKS	Book Reviews	370
HERE'S THE ANSWER	Replies to Readers	344
CONTACT	By The Editor	377

Cover Painting by S. R. DRIGIN (see page 338.)

Most of the Original Drawings in this Magazine are For Sale. Terms may be had on application to the Cliché Dept. (AIR STORIES) George Newnes Ltd., Tower House, Southampton Street, Strand, London, W.C.2.

Subscription Price to any part of the world, post free, for one year 9s. (Canada, 8s. 6d.). Registered at the General Post Office for transmission by Canadian Magazine Post. Published by George Newnes Ltd., Tower House, Southampton Street, Strand, London, W.C.2. Printed in England by The Whitefriars Press Ltd., Tombridge. Sole Agents for Australia and New Zealand: Gordon & Gotch Ltd. Sole Agents for South Africa: Central News Agency Ltd.

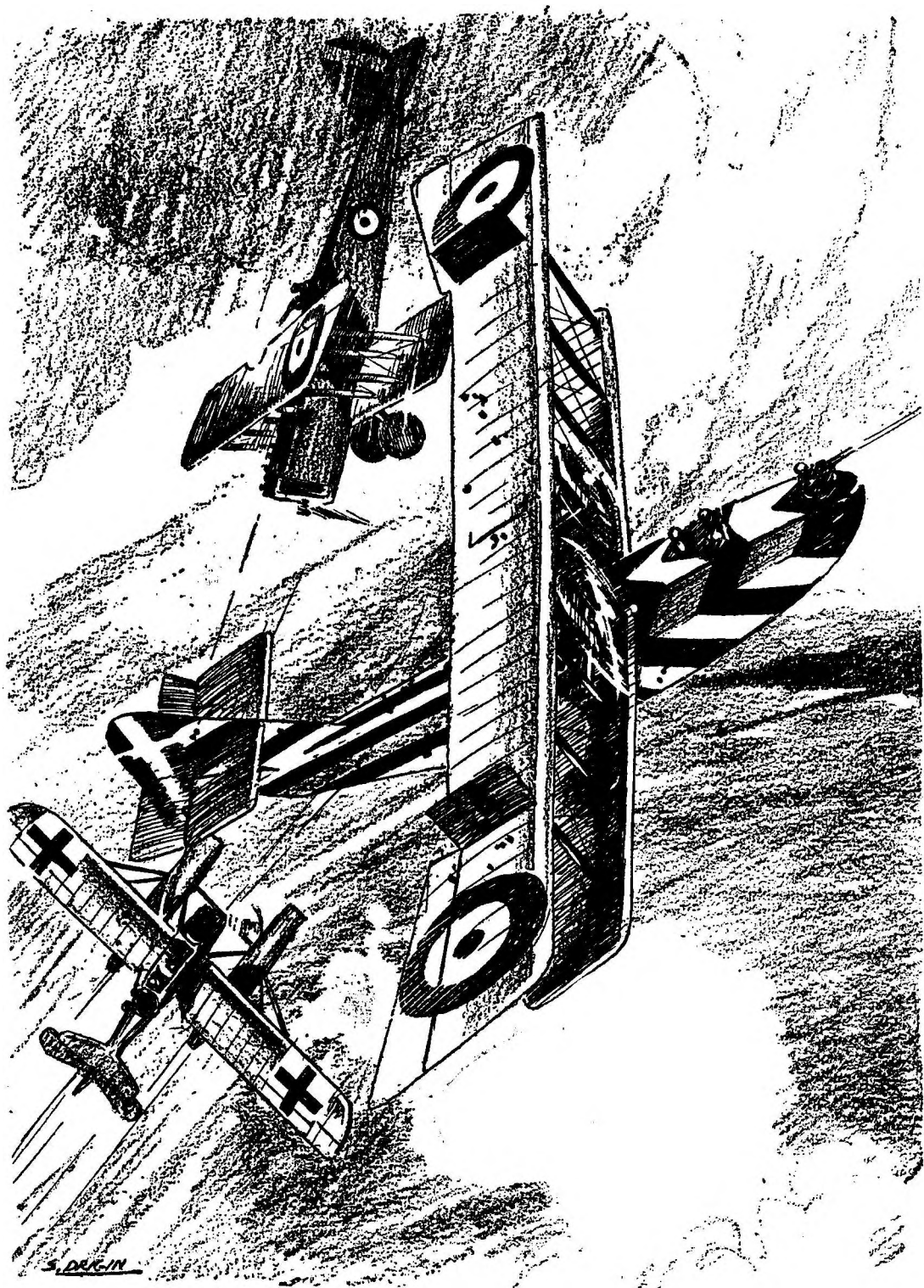

Out of the blue, the D.H.4 plunged upon the Hun seaplane . . .

A Long Complete Story of the Royal Naval Air Service

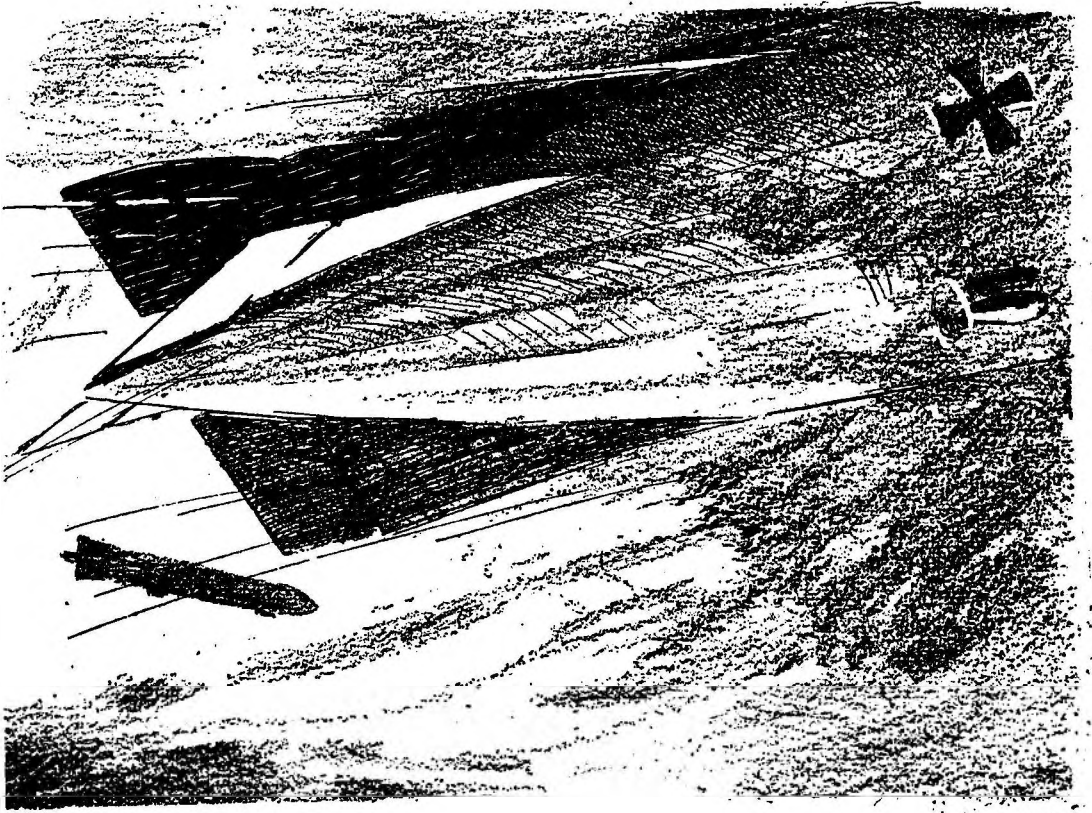

. . . while the front guns of the flying-boat sprayed the tail of the rearing Zepp.

RAIDERS OF THE NORTH SEA

Up from an East Coast Air Station rose the Strangest Patrol of the War, an R.N.A.S. Flying-boat and an R.F.C. Fighter, bound across the Lonely Wastes of the North Sea on a Dangerous Game of Raiding the Raiders

By H. C. PARSONS

CHAPTER I

"Failed to Return"

THE North Sea looked grimmer and greyer than usual to the straining eyes of Squadron Commander Rutherford as he slowly paced the concrete way at the top of the beach. Behind him the hangars, wreathed in a cold October mist, echoed to the noises of overhauling and reloading seaplanes and flying-boats for fresh action.

Except for an occasional glance as

he turned at the top of each slipway, Commander Rutherford appeared to have small interest in the hangars, but kept his eyes on what little of the sea was visible in the mist. The only seaward sounds to be heard were sudden splutterings of the engine of a launch on some business between the mooring-buoys, the ceaseless wash of the sea upon the shingle, and an occasional wailing shriek from some bird over the water.

Petty Officer Black, emerging with a cronym from one of the hangars to get a

AIR STORIES

"breather," aptly summed up the scene.

"Make a ruddy good match, them two!" he remarked.

His companion, not having the same eye for balance, and seeing only the Squadron Commander in the immediate vicinity, reasonably enquired:

"Wot two?"

"Wot two? Why, the Skipper and the North ruddy Sea, o' course, only 'e ain't got no fog about 'im," replied P.O. Black with mixed triumph and reproach. And, indeed, there was reason for this unusual flight of fancy, for the Skipper's face was strong almost to ruthlessness, unemotional, entirely efficient, yet with a sardonic humour lurking in the lines round the mouth and rather stern grey eyes.

For a moment longer P.O. Black surveyed the cold seaward scene, then, with judicious deliberation, spat upon his horny palms. "Come on, we've got work to do," he announced.

His companion did not at once respond to the invitation, but remained looking eastward, moving the worthy P.O. to sarcastic rhetoric.

"Wot the 'ell you staring out there for? Think your mug'll guide the Short back 'ome?"

"Orl right, orl right!" was the aggrieved reply. "I was only wondering where the poor beggar's come down."

P.O. Black's face lost some of its bellicosity as he considered the point, and finally voiced what was in the other's mind.

"Um, not much of a picnic driftin' about over by the Dutch coast this weather, floats leakin', engine dead, no grub, no water, and each ruddy wave knocking bits orf yer wings."

The other took up the running—"Yus. See abaht four 'undred yards, and that's only till night drops on yer, and as much 'ope of being spotted by anybody as you 'ave of becomin' Admiral o' the ruddy Fleet!"

This reflection upon the improbable secret ambitions of P.O. Black recalled that officer to a sense of his immediate responsibilities and, with some asperity, he proceeded to deal with the matter.

"If you think you can stay 'ere orl day on the jaw, take another think! Wot d'yer think you know about it, anyway, ruddy greaser! As like as not the Short couldn't see the station in this stuff and came in up the coast. Anyway, the Skipper'll want the boats ready, so get to it."

AS the pair turned to enter the hangar a faint hum came to their ears, and, as one man, they stopped dead and looked skywards. Commander Rutherford, too, had stopped his restless pacing along the concrete and was looking northward through the mist. It was difficult at first to tell the direction from which the craft was coming, but as the hum grew to a satisfying roar Flight Commander Belton, duty officer of the day, hurried to join the C.O.

"Can't see her yet, Belton, but it's not a Short," remarked the Skipper.

"No, sir," replied Belton, "although this mist's very deceptive. I'm getting an F.2 * out to the slipway in case it's a Hun looking for trouble, and a working party ready to pull the little stranger in if she's one of us and alights out there."

"Good," said the Commander, "and you'd better have some men on the Meadow. She might be a land machine."

The Duty Officer sped away to accelerate the progress of these operations, while the Commander, after a final vain effort to detect the stranger through the mist, walked quickly towards the Stores Hut, a small solid-looking building beyond the last hangar. Climbing the fixed ladder to the flattish roof, he came upon the station's only A.A. gun, at the breech of which squatted an oldish, bearded gunner, hopefully surveying the low clouds almost hidden in the mist, out of which quick death might rush at any moment.

"No, stay there," said the Commander—the loss of one leg at Jutland had made springing to attention a difficult matter

* Produced in 1917 at the R.N.A.S. Experimental Station at Felixstowe, the F.2 flying-boat was one of the largest flying-boats of the War. With two 375 h.p. Rolls-Royce Eagles, it had a top speed of about 95 m.p.h. and weighed 5 tons.—EDITOR'S NOTE.

RAIDERS OF THE NORTH SEA

for the old gunner—"but don't fire until I tell you. She's probably one of ours."

The roar of the engine seemed to come from every direction now, muffled and spread by the mist, and much more exasperation seethed inside Commander Rutherford than showed in his face.

"There she blows, sir," suddenly bellowed the gunner, and added peevishly, "but I may as well go below again. She showed our targets."

"Yes," replied the Commander, "and she was a biggish land machine, too. Sorry to disappoint you, Hawkins. Send up a couple of green rockets. Whoever it is up there may see 'em."

For perhaps three seconds the C.O. had seen a large land machine, apparently a two-seater with British markings, hurtling seaward, not a hundred feet up. The deafening roar of her engine rapidly dwindled to a loud hum, moved round, then gradually became louder.

"Good work, Hawkins, he must have seen your rockets," said the Commander, making for the ladder. "I'll be at the Meadow."

The Meadow was a long narrow piece of grassland at the back of the station, fairly bumpy in patches, but perfectly serviceable as a landing-ground, and used as such by the five land machines possessed by the station—two B.E.2c's, a Sopwith One-and-a-Half Strutter, and a brace of rather ancient Farmans.

It was towards this ground that Commander Rutherford now moved at speed, and as he rounded the hangars another green rocket went up from a party assembled some thirty yards out on the Meadow. Flight Commander Belton was standing by the first of the flares that were beginning to blaze up in the shape of an "L," and came to meet the C.O.

"She's no Hun, sir, but the poor devil in her'll need quite a bit of help in this stuff to keep his keel where it ought to be."

The C.O. smiled ruefully for, although he knew the bad patches on the Meadow, he had wiped off a B.E.2c's undercarriage only the previous evening.

"You're right, Belton," he agreed.

"We ought to be able to see him soon; sounds almost on top of us."

As he spoke the aeroplane shot out of the mist, raced over their heads and circled again out of sight into the mist.

"Evidently inspecting the prospects of a soft landing," remarked the C.O. "Here she comes again."

The party of men bunched together at the end of the "L," and the machine glided past them into the "L" at a good speed, landed like a bird, and taxied up to the nearest hangar.

"Lucky fellow," remarked Belton. "He dodged those ridges as if he knew 'em by heart."

"Yes," replied Rutherford. "Evidently knows his job. Let's have a look at him."

As they arrived, an elegant person had just climbed out of the machine. He was gorgeously clad in a beautifully waisted "maternity" jacket, breeches of a near-primrose hue, gleaming Sam Browne, and, presumably as a concession to his trade, sheepskin boots to his knees, and a rich brown leather helmet.

"Good God!" murmured Belton, "what's this?"

"Royal Flying Corps, Military Wing," answered the C.O. dryly, and turned to greet the newcomer.

CHAPTER II

Captain Ware Comes Aboard

BEFORE Rutherford had taken a couple of steps forward, the R.F.C. officer was upon them.

"Good afternoon, sirs," he announced gaily. "I seek a fishing village yclept Yareton, whereat sundry myrmidons of the Silent Service scud to and fro in their little seaplanes as the waterfowl upon the old home pool. This, methinks, should be the scaly spot, in which case pray lead me to the Admiral."

Commander Rutherford gazed with some sternness upon this incredibly cheerful person who obviously had not yet seen twenty summers. "This is Yareton," he replied. "We have no Admirals here, but I am Squadron Commander Rutherford, in charge of

AIR STORIES

the station. And now, who the devil are you ? ”

With beaming face the other saluted. “ I beg your pardon, sir. I am not well versed in ocean lore, and rather expected a gold cocked hat, frock coat and gleaming lace instead of a sober blue jacket. My name is Ware—Captain Ware, 34B Squadron, Royal Flying Corps, and I’ve brought a D.H.4 to help wage your pirate wars.”

The C.O. ignored the last provocative statement, and shook hands with some heartiness. “ Let me introduce Flight Commander Belton—my second in command—Duty Officer for the moment. By the way, Belton, Captain Ware has some twenty-five Huns to his credit and a flying reputation that I would give a lot to possess.”

The R.F.C. man flushed—and even became serious for a moment—“ Not at all, sir. We’re more in the limelight on the other side, and get more birds to pot in one day than you see in a year. We have all the luck, that’s all it is ; and consequently Generals pin vast quantities of ironmongery upon our heaving bosoms, and certain Gallic bearded pards have even kissed us upon both cheeks.”

“ Horror upon horror,” laughed Belton, “ but let’s have a look at this machine of yours.”

“ Not for the moment, Belton,” said the C.O. “ Captain Ware could probably do with a splash of the old and bold. Flying on a late October afternoon on the coast is not too warming for a sailor, let alone a longshoreman. You’d better have his machine put in the end hangar and cleaned down. Then perhaps you’ll join us afterwards in the mess ? Don’t let ’em touch the inside or engine of the machine. That suit you, Ware ? ”

“ Yo ho, and a bottle of rum,” replied that gentleman. “ We will essay a natty hornpipe or two together, Admiral, and await, with intrepid hearts of oak, the arrival of the Bosun. Pipe away, Bosun, and meet us in the scuppers.”

Belton grinned and murmured reflectively, “ I seem to remember an early axiom of the Service that ‘ Officers of the R.N.A.S. should be Naval officers who

can fly, not flying officers with a rudimentary knowledge of the Navy.’ More in it than I thought, evidently.”

“ Let’s get going, Captain Ware,” Rutherford interrupted. “ See you later, Belton,” he added, and the Duty Officer vanished into the nearest hangar.

“ DIDN’T expect you for a couple of days,” said the C.O. as the two men walked over to the small mess. “ Harwichton told us you would be coming then, and I had no idea who it was knocking around up there. Thought you were a Hun at first. Jerry’s rather fond of planting half a dozen Brandenburgs—small seaplanes—about five miles out to lie in wait for a lonesome machine on submarine patrol, and our pom-pom on the roof there was prepared to welcome you quite hotly. Wonder you managed to find Yareton at all.”

“ Oh, it’s not too bad higher up, sir—though I doubt if I should have landed if you hadn’t shown those flares. For which a father’s thanks. ‘ How like the Navy, George,’ said I to myself, ‘ efficiently combining business with pleasure, toasting the odd kipper or chestnut or what-not, and simultaneously guiding the wandering stranger to port.’ ”

“ Don’t think there’s much in the kipper theory,” laughed the C.O., “ but we can certainly guide you to some sound port if you like. I prefer a peg, myself. Here we are.”

The sole occupant of the mess was the steward, a gnarled, retired Marine with a limp. He rocketed to attention as the two officers stepped in, his eyes bulging at the brilliant apparel of the C.O.’s companion.

“ Is it to be port, then ? ” enquired the Skipper.

“ No, a double Scotch, please,” Ware replied. “ You know, I thought the King’s Navy imbibed nought but panikins of grog twice on Sunday, or when instructed to splice the main brace. Why a brace, except that a brace is a couple, I don’t know, but I suppose that’s the sort of thing you are all taught as tender lads at Dartmoor.”

The C.O. smiled and took up his glass.

RAIDERS OF THE NORTH SEA

"Dartmouth, please. It sounds better, you know. Here's how!"

After a mutual silence during which two throats were satisfactorily cleared of fog, he continued. "When you've finished we'll get along to my hole. I've a large-scale map there and I want to show you the plan of campaign."

Ware drained his glass with a flourish and Commander Rutherford led the way to the door, where he paused a moment to address the steward.

"Sergeant! When Commander Belton comes in, tell him that Captain Ware and I are in the Navigation Room."

"Yes, sir," snapped the erstwhile Marine, quivering at the salute as the pair went out.

The early winter day was drawing to a close and the mist had become an enveloping wet fog as the two officers strolled across the camp.

The R.F.C. officer looked round wryly. "Sunny little resort, this, sir. I suppose you get quite a few fogs during the winter?"

"Yes," Rutherford replied, "we do, but farther out you are likely to get low clouds all the year round. Sometimes in the North Sea there's a maximum ceiling of six hundred feet for weeks on end. May have clear weather here, but not ten miles out there'll be a wide belt of fog—or t'other way round."

"Quite, sir, quite," agreed the understanding Ware. "Tears and Laughter, or Sunshine and Shadow in the Cottage Home. I get the idea. But can you get much yoho-ing and what-not done, with such a caddish ocean to cope with?"

"If you mean work, yes," the Skipper answered grimly. "Unless it's absolutely impossible the jobs must be done; all the patrols—regular anti-submarine, not infrequent convoy, and odd emergency ones, looking for mines and minelayers, locating hostile craft. Then occasionally there's reconnaissance work with the Fleet, and our ever-present job of intercepting Zepps., both going and coming. And if you come down on the water you may float about for days on a grey sea, nothing to eat or drink, your machine breaking up and perhaps a fifty to one

chance of being picked up—rather different from land work, eh?"

"Come, come, sir," laughed Ware. "I believe you're trying to be the bad Old Man of the Sea—'water, water everywhere, and not a drop to drink,' and all that sort of thing."

"No, I'm not," said the C.O., still with a trace of grimness, "but most people seem to think our job's a soft one. You should hear some of the Brass Hats that come down here. 'How is it the Zepps. come and go with apparent impunity when you have all the material and personnel both to repulse and attack them?' That's the sort of footling question they ask. What they don't realise is that here we are, a station with 150 miles of coast to guard and only a few land machines, six seaplanes, and three boats—half of which are usually out of commission owing to the incessant work—to do it with. If we're lucky, we're warned ten minutes before she crosses the coast some fifty miles north or south of here that a Zepp. is making for home, and that we must bring her down with machines that can't get up to even half her ceiling. But that's what I wanted to talk about, and here we are."

CHAPTER III

A Plot is Hatched

THE two men entered the rather bare office that was known as the Navigation Room, and Ware's eyes lit up with enthusiasm when he saw the great map fixed down on the table.

"Jolly little plan of the countryside, sir, though there seems to be an awful lot of blue about it. S'pose you croon over it like Columbus sighing for more worlds to conquer?"

"No, I've known it pretty well, Ware, for some ten years on and off, and I don't think anybody will ever conquer the North Sea. Just as you think you're doing well, it rises up and hits you. But sit down while I give you an idea of the situation. I want to refer to the map now and again, so I'll keep afoot."

When Ware was seated, Rutherford resumed. "As I've already told you—

AIR STORIES

rather heatedly, I'm afraid, but it's the one thing I get excited about—the whole of the great British public, official and otherwise, clamour to know what the coast defence (that's us) is doing when audacious Zepps. are bombing them out of hearth and home every other day. Well, we might truthfully tell 'em that we're flying twenty-four hours out of twenty-four, in all weather, men weary with work and disappointment, yet cheerfully chasing the Hun with hardly a hope of catching him, and all too frequently ending up underneath a damned cold sea. But we don't tell 'em that. All we can do is to bombard Wing with demands for a machine that is at least capable of reaching a Zepp. when we find it."

"Excuse my shocking ignorance, sir," Ware interrupted, "but what is the usual height at which the beggars come in or go out? I've had no experience of them at all on the other side."

The C.O. shrugged his shoulders. "Oh, practically any height they like. They choose dark nights; there are practically no searchlights or A.A. gun defences along the coast, and even if we're warned in time and the location given is accurate, by the time we can get to the spot and to an effective height, the Zepp.'s changed direction and we're done. And even if we do spot it—and as you know from your own scraps, you can be almost alongside another machine and not hear his engines through the racket of your own—Brother Zepp. simply shoots up a few thousand feet above our absolute ceiling and disappears into the clouds. Those fellows can get up eighteen thousand feet or more."

By this time Captain Ware was all attention and had shed much of his airy persiflage.

"But haven't you a 'bus capable of eighteen thousand feet?" he enquired.

The C.O. gave a short laugh, and replied, "Certainly we've got land 'planes that can do it, but the Zepp. would have made her landfall on the other side by the time our man was anywhere near that height. Not only that, they would have to chase the Zepp. over the sea, and what's going to happen if a land machine comes down

there? Still, our lads go on trying it, though quite a number of them have never come back in spite of days of hunting by seaplanes and boats. And don't think the seaplanes can just sit on the water and taxi home, although, of course, they float for some time as a rule. Why, only to-day I've lost a seaplane—I'll tell you about it later."

A RAP at the door interrupted the conversation, and the Duty Officer's face appeared round the door.

"Come in, Belton," said the C.O. "I've just reached the point of showing Captain Ware why we've been howling for machines with a quick ceiling of over twenty thousand feet."

"Well met, Bosun, well met," quoth the R.F.C. man heartily to the newcomer. "Anchors all carefully weighed, and hammocks properly slung to the binnacle? Good, Bosun, good! Consider yourself piped aboard. The Admiral has been trying to freeze my blood by shocking narratives of the woes of the boys in the bell-bottomed trousers as opposed to the Hun chortling in his gasbags." He turned to the contemplative Skipper who was studying the map through a haze of pipe smoke. "All aboard the lugger, sir! I think you were about to complete the illumination of my darkness?"

"I can try, Ware, anyhow. By the way, Belton, anything to report?" Rutherford enquired.

"Yes, sir. Burns and Johnson have just brought their boats in. Burns went nearly as far as Texel, and Johnson searched a good way towards the South Dogger, but saw nothing of the Short. Both report visibility rotten in patches, but clear to the east. Apparently it's worse at Yareton than outside."

The C.O. puffed his pipe in silence, then, almost to himself, murmured: "I'm afraid Peele's gone. But we'll get the devils yet." He ceased gazing at the map and became again the alert commanding officer of a busy air station.

"I expect you're wondering what on earth this is all about, Ware. Belton knows; when he's not Duty Officer you'll usually find him bumbling about

RAIDERS OF THE NORTH SEA

between here and the Frisian Islands. Come and look at the map."

"Yo ho for the Spanish Main," was Ware's flippant reply as he came briskly across to the table, but it was with approval that Rutherford noted the keen eyes fixed to the map and sensed in the taut bearing something of what the man was like in action.

THE three men bent over the map, absorbed in its prosaic markings, although two of them knew its every line.

"Here, as you probably have seen," said the C.O., "is Yareton, and our beat extends roughly up to Hunstantham and down to Harwichton. We have little or no warning that Zepps. are about until they're over the coast, and, once they're inland, the R.F.C. people usually attend to them."

"Yes, several have been collared inland," agreed Ware, "but very many more have got back to their little grey homes in the east."

"Just so," growled the Skipper, "and, having missed them coming in, we're supposed to nab 'em clearing out. The snag is that they don't lounge about on the way back. They fly high, in the clouds if possible, and they naturally choose a dark night. So our chance of even meeting one is pretty slender."

Ware considered a moment. "But I don't see, sir," he objected, "how the possession of a fast 'bus or so with a ceiling as high as the gasbag's would help very much in the situation you've just outlined?"

"No, it wouldn't, but that's where our scheme, which we've been working for a month or two, comes in. The Zepps. generally make their landfall this side late at night and get back to the other side about dawn. As soon as we know they're through we send up a couple of B.E.2c's or any other available land machine."

"Have your land 'buses ever snaffled a gasbag?" Ware enquired.

"No, not yet," replied the C.O. with a reminiscent smile. "Belton, here, once chased one for miles inland with a frozen gun, and five minutes after he'd

given it up an R.F.C. lad got it first time. Another dirty night, after chasing one for an hour out at sea and an hour inland, he was just in position to put some salt on the bird's tail when two cylinder heads blew off, and he landed in a village pond."

Belton took up the tale, "From which point of vantage I had the joy of seeing the damned gasbag made into a bonfire by some lucky pup of the R.F.C."

Ware simulated an air of dignified reproof:

"Come, come, Bosun!" he chided. "A certain amount of exasperation is permissible, even excusable, but never allow the yellow eye of envy to sear your salty bosom. Fate handed you a particularly succulent raspberry, Bosun. Tough, admitted; very tough, but no more."

"May we proceed, gentlemen?" enquired the C.O.

THE R.F.C. man thwacked his hand on Belton's shoulder. "The dear old Bosun and I are all ears, and dumb withal, sir."

"Not so dumb as all that, I hope," replied the C.O. "But you've gathered by now that we haven't been able to do much with our land craft, and that our seaplanes can't reach the height. Now look at this map again. The Zepps. usually make in the direction of London, but, in any case, they've mostly got to get back to the vicinity of Cuxhaven, just here"—the pipe stem stabbed at a spot on the map—"and it frequently happens that they take this route, straight across from our East Coast, up along the Dutch Islands, past their seaplane stations at Borkum and Norderney, and so to safe anchorage. It's a ten to one chance that they come from there."

Ware nodded, deeply interested. "And you propose to singe the King of Spain's beard?"

The C.O. shook his head. "You're going too fast, Ware. What we have been doing after they've raided is to send out seaplanes at dawn; a couple to Robinson's Knoll—that's this point, about

AIR STORIES

half way across—another couple to the vicinity of Haaks light-vessel, off Texel, the first sizeable Frisian island. At the same time the boats make for Ameland, almost the last island, as you see, some forty miles from Borkum, the Hun spawning ground. There they sit and wait for the innocent Zepp. to return, shaking hands with itself, and generally cruising at about five thousand feet."

"Great idea, sir," Ware applauded. "Bold conception plus low cunning. Set a thief to catch a thief, as 'twere. And have you ever caught a thief in these wily toils?"

The C.O. laughed. "Ask Belton," he suggested.

The Duty Officer coughed and was understood to mumble that "the station" had bagged a couple that way, a modest admission that called forth a howl of delight from the R.F.C. man.

"You wicked old Bosun!" he chortled. "Trying all the time to conceal the heart of a lion beneath the belliest-bottomed trousers."

Belton grinned and turned the matter aside. "Your knowledge of anatomy is pretty punk. Anyway, our dawn trips don't all turn out like that."

"No," joined in Rutherford, "and one of the Shorts that went out to wait at Haaks this morning, after last night's raid over London, hasn't turned up yet, and I'm afraid she's gone. The other Short lost contact with her in the mist not twenty miles from Texel, and, as no gunfire was heard, the engine must have packed up."

"Bad luck, sir. Can't we do something about it?" Ware asked.

The Skipper noted, but for the moment ignored, the "we." Although he was too keen on getting his job done properly to have much trace of professional jealousy, it seemed to him that this was primarily a job for the Naval side.

"Yes, it's a bad show," he agreed. "But the chief reason I wanted at least one D.H.4 was this. As soon as Belton or I can handle your 'bus properly we plan to go over to the islands at dawn. There will be just the two boats and the D.H.4, and we hope to meet a Zepp. or

two cruising around the islands and give 'em hell. While they keep low the boats can deal with them, but when they try to clear out above our reach, then the D.H.4 sails up with them or is waiting for them, and, with any luck, there'll be one or two little nigger boys gone."

Ware's eyes sparkled mischievously as he announced: "Of course, sir, I've been lent here for a week or so. But—and mark this well, Bosun, because earlier you were casting a covetously fishy eye upon my 'bus—orders are that whoever else is in her I must also be there until such time as I leave Yareton." He sighed draughtily, and added: "A pity, a great pity. No time like the present, as they say in the R.F.C. And to think of all those proud little Zepps. cavorting around those islands to-morrow."

COMMANDER RUTHERFORD bit upon his pipe, then raised an eyebrow across to the Duty Officer, who nodded sapiently. Then, as one letting another into the secrets of his innermost heart, the C.O. spoke with some deliberation: "Afraid I didn't catch your soliloquy, Ware, but no matter. What is important is that I decided this morning that we would try our luck at dawn to-morrow with a couple of boats and a seaplane. We propose to snoop over to Terschelling—it's about 170 miles as the crow flies, and our land machines couldn't do it there and back. The Zepps. generally take a morning paranda round there, and we could probably surprise them. But now we've got a D.H.4, why not take that with us, too? And since you mustn't leave her, well, what about it?"

The R.F.C. man beamed. "Admiral—for that is the least you should be—whenever you find yourself destitute and starving, start up a correspondence school on telepathy. But a few moments back I muttered beneath my beard your very words. The 'bus is fighting fit, her pilot is—well, modesty forbids—and everything in the garden is lovely. Bosun, hoist the spanker and boom, and away for far Cathay!"

RAIDERS OF THE NORTH SEA

"Good, but we don't go as far as Cathay," replied the Skipper. "Now, what can the D.H.4 do?"

"A whale of a lot," was Ware's enthusiastic response, "but, briefly, she's fast, capable of over a hundred and thirty flat out, climbs to ten thousand feet in about nine minutes, has a ceiling of at least twenty-four thousand feet, and is good for seven hours. Her 375 Rolls engine is a corker. Four guns, too, and altogether a beauty to handle." Then, becoming suddenly aware of his evident enthusiasm, he added: "Of course, sir, we have cheaper lines, but, if you want to be a real Santa Claus, then undoubtedly buy that one for the child. It'll amuse for hours, even if it won't keep the boys at home."

The Skipper concealed his own enthusiasm by lighting his pipe afresh, and remarked:

"Right, I'll buy it. Sounds just about what we want. Now, Belton, you're still Duty Officer to-morrow, so you'll have to stay around. Sorry, but that's that. Have F.1892 ready. I'll take it with Burns as second pilot and your usual crew. We'll send only one boat over this time and see how it goes. With you, Ware, I'll send Flight Lieutenant Castleton. He's a bright lad, been over there a number of times with Belton or myself and knows all about any surface craft or other bobbery you may meet. Also, he's a pretty good gun-layer and navigator. Not that you need much navigation; just keep your eye on my boat, and you'll get there. But you may be separated from me by fog or by—er—enemy action."

"Quite, sir," said Ware. "Mary had a little lamb and so forth. And, as you say, a battleship to me is faintly distinguishable from a peg-top, but little more, and I doubt if I should know a mine from a moth ball. I might even come down to wave kisses to old von Tirpitz under the impression that his ship of war was Jellicoe's private yacht, so the boy Castleton will be welcome."

The Duty Officer, perhaps with some chagrin at losing his chance of a show, had remained silent, but now broke in.

"If you will excuse me, sir, I must get back to the job, and rev. the lads up a bit on your boat. If Captain Ware will come along presently I'll get whatever he wants done to the D.H."

"Mary and Martha all over again," beamed the R.F.C. man. "Good old Martha eager to get on with the cooking while Mary sits at the feet of Gamaliel, or *vice versa*; I always forget which. Right, Bosun, when the Admiral blows the siren, I'll gallop from my moorings like the hunted fawn."

CHAPTER IV

A Co-operative Affair

ONCE more Squadron Commander Rutherford was looking out over the North Sea, but this time with grim satisfaction writ large upon his face. A faint lightening in the east heralded the passing of the night, and he turned to Ware, who was standing by his side. No longer an elegantly clad figure, the R.F.C. man was now dressed in the purposeful bulk of a full flying rig.

"All ready, Ware?"

"Yes, sir. The 'bus is ticking over sweetly on the Meadow, with friend Castleton itching to take-off."

The Skipper nodded. "Good. My boat's coming out in a moment. You'd better get off when we let her down the slipway. Keep pretty close to us, and behind—the clouds will be lowish over there. If you come down we'll try to pick you up, but keep afloat as long as you can. If we have to alight, come straight back."

"Very good, sir," replied Ware. "Looks as if your take-off should be easy work."

The C.O. lifted an eyebrow, then enquired:

"Ever do a belly-flop when you started diving as a boy?"

"By gad, I did," wryly answered Ware. "I can feel the sting this very minute."

"Then you should have no false ideas about the solidity of water. A boat is more or less a flat surface hitting the water at about 60 knots before she takes off, and not flat water either. If it's a

AIR STORIES

bit rough you're damned lucky to get her off without smashing something. Imagine racing a car across the furrows of a ploughed field, and you'll get some idea of it."

"Good Lord!" murmured Ware, "and I thought it would be as simple as buzzing down a water-chute!"

A terrific bellow of "Haul on her starboard tip there" made both men jump round, to see the stately F.2 proceeding out of her hangar on a trolley fitted to her hull bottom. A party of about twenty men were hauling and pushing under the stentorian direction of Flight Commander Belton.

"Good old Bosun," Ware laughed. "But why such a crowd of minions to aid and abet him?"

"She's heavy, about five tons," replied the Skipper. "And that wing span's not far short of a hundred feet—makes her awkward to handle."

The R.F.C. man eyed the great flying-boat with absorbed interest as it was wheeled near the top of the slipway. Its most striking feature was perhaps the hull, curved from bow to stern, with the tail lifted well in the air. The lower plane appeared to be built into the hull, and above it were fixed the twin engines, one on either side, close to the centre line of the hull.

"Workmanlike job, sir," remarked Ware. "The engines look much like mine."

"They're the same," answered the C.O. "Rolls 375's. They push her along at about eighty-five to ninety knots, and she's good for eight hours at a sixty-five knot cruising speed."

The R.F.C. man surveyed the F.2 with a professional eye. "How do you protect your tail, sir? Looks pretty difficult to me."

Rutherford smiled. "True enough, Ware. The tail is our one blind spot, and although we boast six guns, none of them could reach anything immediately behind the tail."

that they were waiting to start up the flying-boat's engines. Once again Commander Rutherford impressed upon Ware the importance of keeping close formation with him and then walked away to his waiting boat and climbed into its cabin. The trolley wheels had already been chocked up, and after a few splutterings the engines were ticking over. For about ten minutes they were allowed to warm up, while the crew busied themselves about their various jobs. At last the Skipper waved to Belton; the chocks were removed, and slowly the great boat was wheeled to the top of the slipway and turned with its bows pointing to the sea.

"Quick with that hawser," roared the Duty Officer, and, with the speed born of practice, the end of the cable lying unwound on the sturdy winch near the slipway top was attached to the trolley.

"Let her go! Steady there! Easy on the starboard wing!" came the order, and the F.2 on its trolley slowly began to move down the slipway, while men of the working party kept her straight by timely pushes on each side of the hull until boat and trolley finally came to a stop some feet from the water.

Meanwhile, Burns, the second pilot, had taken up a position in the forward cockpit ready to tug the quick-release line that held the boat on the trolley. His eyes were upon Rutherford, who, after a practised glance around, waved his hand to Belton, standing by the winch.

"Let her go," snapped Belton to the winchman, and in a trice the winch was freed and the boat running down to the water by its own weight. The twin engines increased their mutterings to a more purposeful beat, and the boat advanced farther into the sea until her buoyancy lifted her from the heavy trolley. Simultaneously, Burns, who had been watching the trolley as if his life depended upon it, pulled the release line of the trolley fitting, saw it fall away, and held up his hand for the Skipper's information.

At once Rutherford slightly advanced the throttles, and the F.2 moved slowly

FURTHER conversation was prevented by Belton, who hurried up to announce

RAIDERS OF THE NORTH SEA

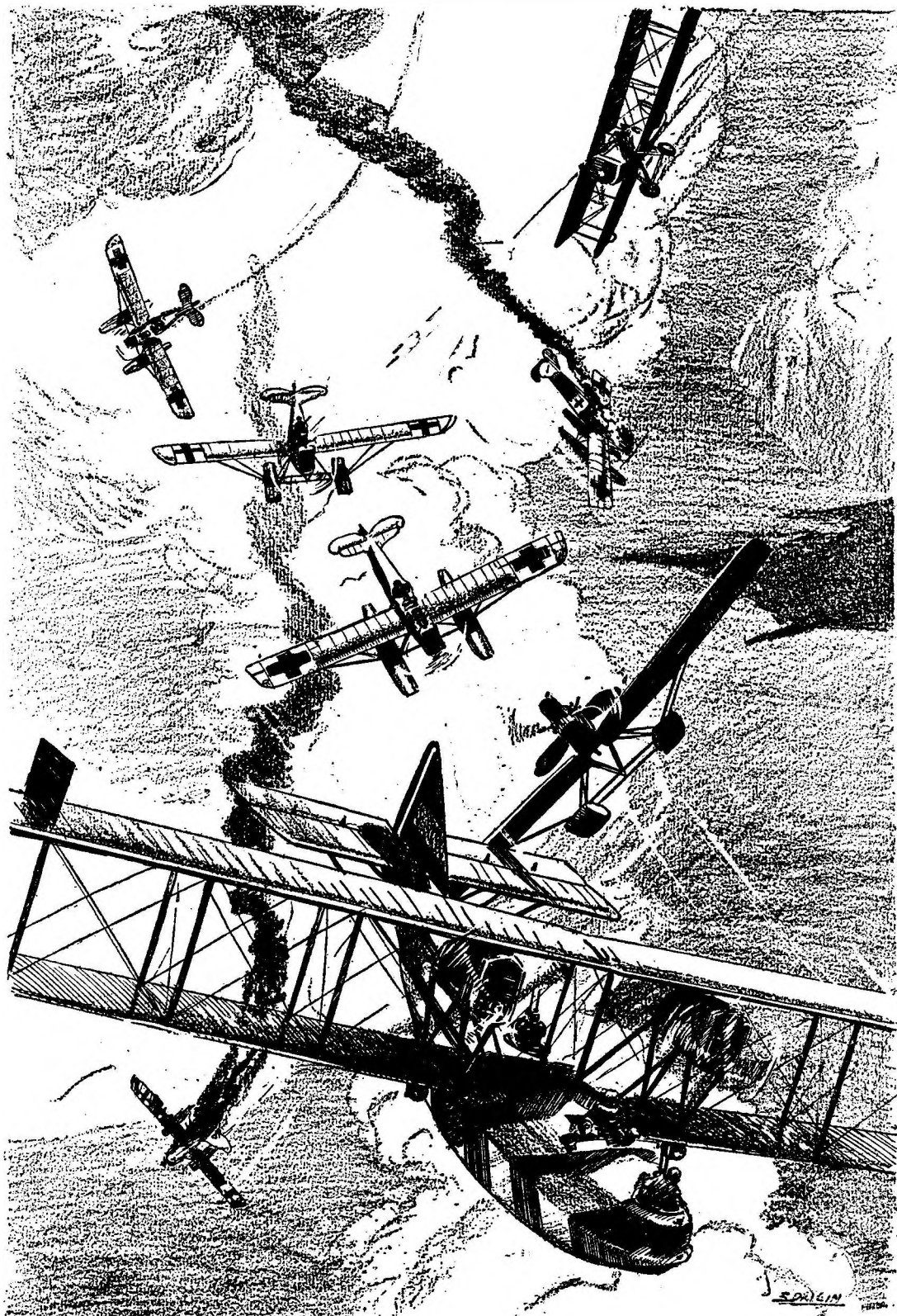

As the line of Brandenburgs re-formed for the attack, death dived among them in the shape of a hurtling D.H.4

AIR STORIES

out to sea and into the wind, ready for the take-off.

"Any sign of the D.H., Burns?" Rutherford enquired of the Second Pilot, who had now clambered back from the forward cockpit and was watching the station on shore.

"Yes, sir, she's just coming up over the end hangar."

"Right! Now for it," replied the Skipper.

The two Rolls engines increased their thunder, and hearty slaps reverberated beneath the hull from the wave-tops caught by the speeding boat. The Skipper fixed his eyes upon the air speed indicator, keeping the F.2's bows out of the water until the instrument showed an air speed of fifteen knots. Then, pushing the control wheel slightly forward until the tail was lifted enough to bring the boat into the horizontal position on the forward step, the Skipper gave a terrific roar of "Stand by," and the crew promptly grabbed hold of anything firm within reach. Faster and faster sped the F.2, until the savage hammering of the wave-tops upon her bottom planking shattered all hearing and threatened to stove in the hull itself. But the crew knew well enough that the boat had not yet reached her flying speed of sixty knots, and bore the jarring racket with the stoicism of experience.

"A near one, that," muttered the Skipper, as an extra tall wave tried to fling the boat off the surface, and he had to exert his full strength on the stick to keep a following deep trough from deflecting her bows downward.

A few more seconds and, just when it seemed that each new smashing blow on the bottom must surely cleave the hull in splinters, the air speed showed sixty knots. The pilot eased back the stick, the F.2 rose not ungracefully into the air and the even roar of the twin-engines sounded as mild music compared with their recent appalling clamour.

"Nice work, sir," said Burns.

"Not so bad," replied the Skipper. "Those forty-five seconds from the stand by to the actual take-off need more care

than all the rest of the works put together."

"Yes, sir. And what I can never understand is how the boats ever stand up to that awful hammering."

The C.O. was too busy watching the altimeter and the rev. counter to reply. At a thousand feet he throttled the revs. down from one thousand eight hundred to one thousand six hundred, and again, at fifteen hundred feet, he reduced to one thousand four hundred revs. Then, consulting the compass, he set the steadily humming boat in the direction of Holland at a regular sixty-five knots cruising speed.

Seizing a length of fat Sandow elastic, the Skipper next attached a piece to the rudder-bar, stretching it until the rudder control was fixed at points at which the boat would keep a straight course, needing only an occasional touch on the stick to keep her level. The boat, thus trimmed to his satisfaction, the Skipper sat back and surveyed the scene.

"Not much wind at present," he remarked to Burns. "Better take a rough bearing abeam of Dewarp buoy. I fancy it will have changed direction a bit."

"Aye, aye, sir—hello, here's the D.H.4 coming up fast on our starboard quarter. By Jove, sir, she looks a peach—I mean, for a land 'bus."

The Skipper looked round at the D.H.4 hurtling along at about eighty knots some one thousand feet above the F.2. "Yes, Burns, a fine machine and a fine pilot. If we get some action the other side, you'll see some real flying."

The D.H. banked vertically and levelled out to shoot back over the flying-boat. Then she came round again in another steep bank, climbed to about four thousand feet, and took up station some five hundred yards abaft the F.2, evidently throttling down to keep station with the slower machine.

CHAPTER V

"Action Stations"

MEANWHILE, the crew of the flying-boat had busied itself with routine

RAIDERS OF THE NORTH SEA

business. The wireless man unwound his aerial, tapped out a few signals, adjusted the set to his satisfaction and then had a friendly word with the carrier pigeons in their box. The engineer gazed lovingly at his petrol tanks, wiped a streak of oil off a gauge with a lump of cotton waste, and unconsciously transferred the black grease to his brow in an endeavour to remove some of the accumulated perspiration. P.O. Black observed the effect with disdain.

"Put a dollop of powder on yer nose, too," he suggested. "It wants a bit o' something to cover that up."

His comrade-in-arms turned a blood-shot eye upon him and hissed, "You look after yer ruddy guns. Gunlayer, my eye! Yer couldn't lay a pullet's egg!"

The obvious truth of this piece of natural history, together with the fact that the Skipper's cold eye was turned in his direction, caused P.O. Black to retire to the aft cockpit, where he examined the port and starboard sliding doors covering the machine-gun ports, and cast an eye upon the neatly piled ammunition.

The Skipper made some slight adjustment to the elastic holding the rudder-bar after receiving a bearing from Burns, and the crew settled down to an uneventful hour or so while the F.2 ate up a hundred miles of barren sea.

"LOOKS a bit thick ahead, sir," said Burns after a time. "I've noticed once or twice that the D.H. has been hidden by this mist that's blowing up."

"All the better for our purpose," replied the C.O. "It's generally patchy well towards the Haaks vessel, and if we can pop out on them from a bank of fog, they won't get away so easily."

The Second Pilot peered downwards. "D'you know, sir, I haven't seen a single thing, sub. or surface craft, since we left. Thought we might spot the Short drifting about."

"If we see it at all, I think it'll be farther north." The Skipper looked through his glasses a few points south of his course and grunted, "Good,

there's the Haaks vessel; we'll alter course now for Terschelling."

The elastic holding the rudder-bar was duly released, and the Skipper swung the great boat to the north.

"Is the D.H. turning?" he asked.

"Yes, sir, and she seems to be climbing," came the reply.

"Probably he can see clearly over that haze ahead, and prefers to keep above it. Ware knows what he's about. Better get the reception committee ready, I suppose."

Burns nodded, and felt the same old thrill as on his first "show" when the Skipper roared out "Action stations!"

Automatically, each man of the crew took up his post. The wireless operator left his set and went through to the forward cockpit, where he tested the locks and swivels of the Scarff ring on which his twin guns were mounted. The engineer gave a perfunctory glance up at the engines, then passed into the rear of the hull to uncover the side ports and adjust the two machine-guns ready to be swung outboard. The gunlayer posted himself on a small companion ladder by the top aft gun, while Burns connected his controls to those of the Skipper and then clambered into the front cockpit and fondled the gun mounted there. The boat swept on to the north, bristling now with menace from its six guns and the quiet men behind them.

Steadily the haze became thicker, until, soon, visibility was a bare hundred yards. There was no sign now of the D.H., but it was hardly likely that they would be able to see her through this haze, and the Skipper was not worried. He looked at the dashboard clock and calculated that the boat must be nearing Terschelling.

For a few minutes the fog lay thick about them, then all at once it vanished magically, and, looking back, they appeared to have emerged from a wall of white haze which rose to some four thousand feet.

"Enemy craft ahead, sir," bellowed Burns from the forward cockpit, though his warning was unnecessary, for Ruther-

AIR STORIES

ford had seen them at the same instant. Not a quarter of a mile away, cruising gently about in the sunshine, were two great airships, one at about three thousand feet and the other a thousand feet higher. They had the appearance of two enormous prehistoric slugs, possessed of power to float in the air, rambling about in front of their lair, for Terschelling could be seen in the background.

The Skipper opened the throttles until the air speed needle moved slowly round to eighty-five knots, and with a gleam that boded little good to any opponent, he made for the nearer Zepp. He was slightly irritated by the non-appearance of the D.H.4, but well content that his boat should have first smack at the Hun.

The airships did not seem to notice the rapidly approaching flying-boat until it was almost within range and too close for the nearer Zepp. to put about and try to run for it. Next moment the fight was on.

THE F.2's increased speed had enabled her to reach the airship's level by the time she was within range, and Rutherford was congratulating himself on his manœuvre when suddenly the Zepp. nosed up some twenty degrees, and with helm hard over, shot up above and across the flying-boat. The Skipper, however, had kept his eye on the island of Terschelling, and the airship's manœuvre, quickly as it was effected, was too late, and the guns of the F.2 sprayed the underside of the rearing Zepp. as it swept over them. But the attack, withering though it had seemed, had no visible effect, and Rutherford swore tersely, partly at the airship's apparent escape and partly at the absence of the D.H., as he brought the F.2 round and prepared to climb.

"Enemy seaplane abeam," roared P.O. Black from aft, and again the Skipper swore, for this attacker was approaching the boat's one blind spot. Before he could cope with this new danger a spatter of bullets rattled along the hull bottom, and he promptly swung the F.2 round and down to give the other guns a chance to bear on the seaplane.

Again he was too late, but this time, like a flash of lightning, the D.H.4 appeared from out of the blue and came diving at a terrific pace upon the Hun seaplane, its nose guns spitting out twin lines of death. The German staggered, wavered, appeared to recover for a moment, then dropped like a stone into the placid sea, leaving only a few floating fragments of wing to mark its passage.

The D.H. levelled out, and as it roared past the F.2, Ware could be seen waving a gloved hand and pointing upwards before he swung round again in pursuit of the second airship.

In concentrating upon the Hun seaplane, Rutherford and his crew had temporarily lost sight of the airship they had attacked, but now they returned to the chase and immediately saw the reason for Ware's gesture. A thousand feet or more above them, the Zepp. was painfully climbing, while a wicked little tongue of flame licked along the top of the envelope towards the nose. Even as they watched the flame grew and spread with awful speed towards bow and stern. A burst of orange fire from aft and the stern dropped until soon the whole ship, enveloped in flames, hung poised vertically in mid-air like a great torch. Then came an explosion that seemed to split the very sky, and the heavier parts of the airship plunged into the sea followed more slowly by great pieces of burning fabric. Quickly the water absorbed the flaming fragments, and soon there was no trace remaining of the holocaust—just a sullen sea, a bank of fog westward, sunshine over distant Terschelling, and, in the far distance, the second airship fleeing with the D.H.4 in hot pursuit.

"Poor beggars! They 'ad a short life—'ope it was a gay one," was the airship's only epitaph from P.O. Black as the F.2 turned to catch up with the running fight ahead.

CHAPTER VI

Battle of the Brandenburgs

FOR some reason the airship was moving at about half speed, and

RAIDERS OF THE NORTH SEA

Ware appeared to be enjoying himself immensely, roaring along one side of the great Zeppelin, climbing up and diving steeply upon it with spitting guns.

"See anything funny about her, Burns?" roared the Skipper, as the F.2 boomed along, now parallel with the Zeppelin, but out of gun range.

The Second Pilot stared through the glasses for some time, and suddenly bellowed back, "Prop. of port gondola's not running, sir. Whole gondola looks knocked about."

"Right," yelled back the Skipper. "Keep your eyes peeled for seaplanes from the nor-east."

By this time the D.H.4 had climbed to a position immediately above the airship, and, as the F.2 crew watched, it seemed to dive almost on to the top of the monster, dropping its two bombs in quick succession. The first fell short, but the second must have dropped dead in the middle, for the airship seemed to collapse amidships, her bow and stern majestically lifted towards each other. Her back broken, the great Zeppelin crumpled up and dropped like a plummet into the sea.

"Six seaplanes to the nor-east," roared the wireless man suddenly from his forward cockpit.

The Skipper, gazing ahead, quickly spotted the seaplanes and saw that they were monoplanes. "Six Brandenburgs," he growled with sombre satisfaction. "We owe those blighters a knock or two." He looked round for the D.H.4, and was startled when it raced alongside the F.2, its pilot making strange motions with his hand.

"Tell him we're attacking, Burns," shouted the Skipper.

The Second Pilot pointed forward and clenched his fist, a mystic sign that Ware evidently understood, for he opened his throttle, grinned heartily, and climbed away at high speed.

"Knows his own game, I s'pose," murmured the C.O. "Here they come."

Intently the crew of the F.2 watched the rapid approach of the enemy machines. Until they were fairly near they flew in a double line formation, but now they

suddenly changed to a single line, circled behind the flying-boat, and dived down from behind upon the tail.

Anticipating this form of attack, the Skipper instantly hauled the boat round, just in time to save his tail from the full force of the attack. And as the line of Brandenburgs hurtled down past the F.2, to the accompaniment of a hail of Spandau lead on the hull, P.O. Black roared "One ruddy Brandy-ball," and with placid satisfaction peered at the stricken machine plunging into the sea.

HURRIEDLY the enemy seaplanes resumed formation ready to dive afresh, but, while they were yet six or seven hundred yards away, death dived among them in the shape of a hurtling D.H.4 piloted by a man whose gunnery was a byword among men whose daily life depended on their skill with machine-guns. The last of the Brandenburg line twisted down in leaping flame, while the one in front of her fell away like a wind-blown leaf, her pilot riddled with lead. The remaining three seaplanes had already started their dive, unaware of the menace behind them, and, at the first crack of their Spandaus, the F.2's wireless man quietly slid to the bottom of his cockpit with a bullet through his brain. But the boat had again half-turned, and the last of the line received the full force of P.O. Black's gun.

"Chalk up No. 2 ruddy Brandyball," commented that worthy as one putting up a fair average at darts, and deftly placed a fresh drum on his gun while his victim went spinning down into the waiting maw of the sea.

"Burns," shouted the Skipper, "get to the forward cockpit and take over the guns."

Moving the dead operator to one side, Burns steadied himself by the Scarff ring. In a moment his guns were crackling venomously at one of the enemy 'planes that, having climbed to dive up on the D.H., had now changed direction and was hurtling dead on to the F.2.

A vicious stream from its Spandaus bit into the flying-boat amidships, reducing the wireless set to a thing for the

AIR STORIES

scrap heap. Simultaneously the Second Pilot forward and the gunlayer aft caught the Brandenburg in a barrage of lead, and the now unguided machine missed the F.2's top plane by a foot and plunged blindly into the indifferent sea.

"Good work!" bellowed the Skipper encouragingly to the crew at large.

"With knobs on," remarked P.O. Black in an aside to the engineer. "A nap in Brandyballs and a deuce in gasbags." Then suddenly he roared, "'Planes coming up from the north, sir," with about as much emotion as a newsboy announcing the result of the three-thirty.

A GLANCE to the nor'ard revealed a number of dots. There were at least a dozen of them, evidently dashing to the scene of combat.

"Zeppelin called up Borkum, I s'pose," Rutherford muttered. "Time we cleared out." Leaning forward, he shouted to Burns, "Get the Aldis and signal Ware to break off and make for home. She's just coming round after that other Brandenburg."

By a stroke of luck Ware caught the signal just before he opened out after the remaining Hun, now some distance away, and, with a swift turn, he made for the bank of thick mist to the south-west. The F.2 followed, and soon found it was difficult to see a hundred yards in any direction as the clammy mist enveloped them.

"Might try to get above the stuff, Burns," commented the Skipper, "but we can't spare the juice to climb. Still, we've had it worse than this. Hope the D.H.'ll get through it all right.

The crew busied themselves clearing their quarters and preparing for fresh action at any minute. The dead man was moved out of the forward cockpit, and Rutherford concentrated on his course. Around them wreathed the dead grey mist, and below, but seen only in patches, lurked the sullen sea.

Minute after minute droned by, the mist thinning to an eight hundred yards visibility in places, then thickening to a

blinding fog. For mile upon mile they sped along in a world of their own, so that it was almost with a feeling of relief that Rutherford heard a yell from the forward cockpit, "Surface craft to starboard!"

Glancing down, the Skipper throttled back, and descended in a steep spiral to within a hundred feet of the small piece of wreckage that Burns had sighted on the water.

"Isn't that a man hanging on to it?" shouted the Skipper. A nod of agreement from the forward cockpit was followed by Rutherford's roar of "Stand by to alight!" The F.2 made a wide circle, and, still travelling at some sixty knots, alighted in a flurry of foam, to bring up a few yards from the wreckage.

All that could be seen was the tail unit of an aeroplane flaunting the red, white and blue target, and the arm of a man who was evidently clinging to it.

"It's not the Short, anyway," opined the Skipper, but what more he might have said was drowned in a lusty voice near at hand bawling.

"A life on the ocean wave, tra-la, Oh a life on the angry deep," which cheerful noise was promptly smothered by an angry wave from the deep so invoked.

Already Burns had kicked off his flying boots and ripped off his Sidcot suit ready to dive from the forward cockpit, when, after a splutter, the voice was again lifted in exhortation:

"Hang on, laddie, the whole of the King's Navy is searching for us somewhere" (several gurgles) "Oh, Lord, you're heavy" (gurgles, gurgles)—then, not very tunefully: "My body is over the ocean, my body is over the sea"—here a frolicsome wave turned the wreckage clean over and in a second, two dripping bodies were hauled aboard the F.2. One appeared to be unconscious, but the other sat up, pushed his wet hair from his eyes, and revealed the unabashed face of Captain Ware to the amazement of the crew of the F.2. Staggering to his feet, Ware held out a moist hand to Rutherford, "Doctor Livingstone, I presume, sir!" he remarked.

RAIDERS OF THE NORTH SEA

CHAPTER VII

Adrift in the North Sea

RUTHERFORD grasped the extended hand.

"Hurt, Ware?" he enquired.

"No, sir," Ware replied, "but this boy's shoulder's shot to pieces, and he's not too good."

"Black," called the Skipper, "give a hand to get this officer into the after cabin."

"Aye, aye, sir," responded the imperturbable Black, and added, "The boat's leakin' pretty fierce amidships, sir."

"Not surprising with all that lead buzzing about," said the Skipper. "Have to bale her the rest of the way. She certainly won't lift two extra."

When Castleton had been settled as comfortably as possible, Rutherford returned to his cabin, to find Ware surveying the damage done to the boat.

"Sorry about all this, sir," the latter remarked. "One of the Huns evidently pipped our petrol tank, and we ran as far as possible before dropping. The boy put in some great work, but a gunner on the gasbag got him. That Hun sportsman had guts, too—kept on at us when his ship was rearing up in two pieces and he hadn't a hope."

"Yes, their air crowd are great scrappers, but I think they met their match this time. We'll talk about it later. Hi, Burns! Come amidships a moment."

BURNS scrambled along to the cabin, and Rutherford instructed him to continue taxiing the F.2.

"The wind's much the same as when we started," he explained to Ware, "so we know the drift approximately. Of course, we can't take-off with this extra weight, so we must toddle into port like this. I've set a course for the lightship just north of Yareton, though it'll be the devil's own job to keep to it. Burns and I will take turns to navigate and everybody except the pilot will have to bale like Old Harry. The gunlayer and engineer will look after the stern, and you and

Burns will have to do your best amidships. Pity the bilge-pump was knocked out of action in that scrap."

"*Ich Dien!*" responded Ware. "I've always rather wanted to be a bailiff."

"Fine," Rutherford replied. "Then how about starting?"

The R.F.C. man promptly seized a petrol-tin and began vigorously to hurl water over the side, meantime bellowing "Men must work and women must weep" with sufficient power to be heard above the thunder of the engines.

"Hapgood," Rutherford shouted to the engineer, "you'll have to stop baling and come and hand-pump petrol."

"Aye, aye, sir," said the engineer, hurrying forward.

Ware looked up from his baling and enquired of Burns, "Tell me, Admiral-to-be, what signifies all these instructions to the gallant Hapgood?"

Burns looked puzzled for the moment, then smiled. "Oh, that's the pumping business," he explained. "You see, our petrol pumps are wind-driven, but, of course, taxiing along at this speed would hardly revolve a feather propeller. No good except when flying, so the lad has to hand pump petrol into the 'ready-use' tanks. Otherwise the engines'd stop and the boat'd broach-to."

"A clear and lucid explanation, Comrade. Talking of 'broaching' and 'tanks,' do we carry any fresh water in this floating hotel? It'd be a soothing change from the gallons of salt water I've swallowed and am now forced to gaze upon."

Burns reached for the drinking water container. "Here you are. But go easy with it, we haven't too much of it."

Ware looked pained: "Sir! Do you think I am one to take the milk from the infant mouth. Away! Thy need, or somebody's, is greater than mine."

The Skipper looked round, "That's all right, Ware. We've enough, and we haven't been hanging about in the water. Burns, take a spell at the wheel, will you?"

The Second Pilot took the controls while the Skipper made his way aft with a baling tin. "How's it going, P.O.?"

AIR STORIES

he enquired when he reached the labouring gunlayer.

P.O. Black straightened himself, "Bit wet, sir. The seas are steeper than they were and we're shipping a lot of water. But it looks as if the aft bulk'ead is 'olding."

"Good!" Rutherford answered, and turned to see how Castleton was faring.

The wounded man was still and pale, muttering incoherently to himself. Fixing him more securely against the rolling of the sea, Rutherford was about to begin baling when a tremendous lurch sent him back to the control cabin where Ware was picking himself off the wheel.

The luckless R.F.C. man turned a green face to the Skipper, "The boat's pardon, sir! You don't happen to have any Mother Siegel's about you? No? Well, well." He clutched his mouth desperately and murmured, "When that which comes from—ouch—out the boundless deep turns again home," and promptly heaved his heart out over the side.

"Cheer up, Ware," laughed the Skipper. "It's only a capful of wind at present, and the sea's pretty quiet."

Ware slowly raised himself from the side of the boat, seized his baling can and feebly but determinedly set to work again.

"Sorry, Ware, but we've got to keep on or the sea will have us yet. Probably better for you to keep going than not."

"Not another word, sir. Never shall it be said throughout marine circles that Ware of 34 Squadron had never seen Nelson's signal."

The Skipper cast an anxious glance at the dials on the dashboard and turned to his second in command.

"We've had a couple of hours now, Burns, and I reckon it'll be another two before we arrive. We were about twenty-five miles out according to my reckoning and the seas are becoming steeper. Take a spell at the can, will you?"

AND so it went on through the cold day, the crew baling without rest, all their drinking water gone, half a gale

blowing up, nightfall not far away, and a delirious man aft alternating groans with screams of pain.

Every now and again Ware would start up what he conceived to be a sea shanty, but his sickness and the presence of the dead wireless man, combined with the generally depressing outlook, soon defeated any attempt at cheerfulness.

Rutherford seemed to be everywhere, lending a hand and giving his worn-out crew a brief word that meant another willing effort. Soon what little light there had been vanished into darkness, and a rising cross-wind called for all the strength and skill of the Skipper who by now had taken over the navigation entirely. Somehow he kept the boat from broaching-to, anticipating the smashing waves, miraculously saving the wings from being battered to pieces, and all the time holding the boat on her course. No sign of the grim strain appeared in his face save that his mouth was set even more sternly than usual. For hour after hour the boat drove on with no sound but the roar of the engines, the clink of baling tins, and the smash of the sea on the hull, followed by the heave and plunge of the flying-boat.

"How do you like flying-boats now, Ware?" asked the Skipper suddenly, still peering ahead.

With a great effort the baler stood erect, pointed a hand to the darkness aloft and, after swallowing twice, was about to declaim dramatically when—

"Lights on the port bow!" yelled Burns.

Rutherford stared ahead and to port. "Good, that'll be the lightship. Not so bad. Try a flicker with the Aldis, Burns; the mist's thinner here."

Promptly a series of staccato flashes stabbed the night's blackness, to be met with an immediate response in the shape of a searchlight, not five hundred yards to starboard. It dimmed, and an answering series of twinkling dots and dashes came from beside it.

"Armed trawler 'Elizabeth' coming alongside," interpreted Burns to the Skipper, who was still wrestling with the control wheel.

RAIDERS OF THE NORTH SEA

"Good. Take a spell at the wheel, Burns. I'm going aft." As he gained the stern P.O. Black ceased his paddling and brought his baling tin to attention.

"Nearly there, Black," Rutherford told him. "Lightship's a bare mile off and there's a trawler coming alongside. How's the patient?"

"Just dropped orf to sleep, sir. Thought you'd be fetching the lightship soon. Hull's shipping a lot more water, sir."

"Expect it is. Pretty heavy seas, but we'll soon finish now," said the Skipper, turning back to his cabin.

Meanwhile, the searchlight's steady beam had swept forth again, and was now fixed on the F.2 as the trawler came rapidly nearer. Rutherford stepped into the control cabin and relieved Burns of the wheel as the trawler slid alongside, for the process of securing tow-ropes in a sea like this needed care.

A lusty hail from above cheered the waiting crew. "Glad you're through, sir. Yareton wirelessed us two hours back when your pigeon arrived, and we've been cruising around ever since. We can tow you all the way. Are you all staying aboard?"

The Skipper thought for a second, then shouted back. "No. We've one man dead here and another pretty sick, but we'd better not shift him. Captain Ware and two P.O.'s will come aboard you, but I want three men down here to bale, and some brandy if you've got it!"

"Right, sir. 'Ware the rope!"

Burns neatly fielded the rope.

"Make it fast to the bollard amidships," instructed the Skipper, "the boat won't sheer so much."

The transfer of crews was effected and the ropes made fast in the minimum of time possible in a nasty sea, and soon the F.2 was heaving along in the wake of the trawler. But it seemed a long time before the large Yareton launch met them and took on board Ware, Burns, the two P.O.s and the unconscious Castleton, leaving the Skipper on board the F.2 with the new balers and the dead wireless man.

IT was but a pale ghost of the R.F.C. pilot that staggered onto the slipway

after Castleton had been lifted out, but he greeted the wondering Belton with a brave shadow of his old spirit.

"No more for me the hairy hornpipe, Bosun! Gone is the bait of the bell-bottomed trouser." He lurched, and Belton grabbed his arm to steady him.

"Hold on, old son, we'll make for the mess and a refresher."

The R.F.C. man leaned hard on Belton's shoulder and whispered hoarsely, "Tell it not in Gath, Bosun, lest the daughters of all the little fishes rejoice, but Ware of the 34th has been involuntarily feeding the submarine denizens. So now, for the love you bear me, lead me away to a spot that doesn't sway."

Elsewhere, P.O. Black, in intervals between the slaking of his thirst, was deliberating with a sceptical compeer, "Fly? *FLY?*" His look of scorn withered the soul of the listener. "Open those elephant flaps o' yours an' listen, you hijous barnacle! We was five—an' that's countin' me an' the Skipper as only one apiece—an' we got a gasbag an' three Brandyballs."

A lengthy retirement into the tankard followed, then, "This bloke an' the lad—that makes jest two of 'em if yer know how to count—gets a gasbag an' three Huns separate, an' ter my mind, saved the boat! So now wot?" and the speaker returned triumphantly to his tankard.

"That's orl right as fer as it goes," returned the crushed one with an access of spirit, "but 'Apgood told me that the pore feller spewed 'is 'eart up for three hours on end!"

P.O. Black considered this point for a while, and finally delivered himself of a weighty conclusion, "That's right enough, altho' 'Apgood said it." Further deliberation—"But it's like this 'ere. An 'awk an' a gull are both good scrappers, but the gull knows the sea and the 'awk knows the land. An' altho' I ain't sayin' that the gull wouldn't be 'andier at looking after 'isself, they'd be orl wrong if they changed stations."

Which statement, after all, is undeniable.

FOREIGN FIGHTERS—

*Remarkable New Warplanes of Soviet Russia,
Holland and the United States*



A RUSSIAN 4-GUN FIGHTER

ONE of the latest Soviet Russian fighters of which we hear so much and see so little, this single-seater is very reminiscent in general appearance of the R.A.F.'s new Vickers-Supermarine Spitfire fighter. Known as the Type 2KB-19, it mounts an M.100 liquid-cooled engine, reputedly

capable of developing 1,300 h.p., and has retractable wing radiators and undercarriage. It is fitted with four guns, two projecting through the leading edges of each wing. All details of performance and dimensions are secret.

WITH the ominous name of *Le Faucheur* ("The Reaper"), Anthony Fokker's newest product, the Type G.I, has been designed for fighting, bombing or reconnaissance work, and is estimated to do 292 m.p.h., with two Bristol Mercury VII

engines. The crew of two sit in the central nacelle, in the tail of which is a rotatable machine-gun turret to repulse attacks from the rear. Four fixed guns, two 23 mm. cannons and two 7.9 mm. machine-guns are carried in the nose. As a

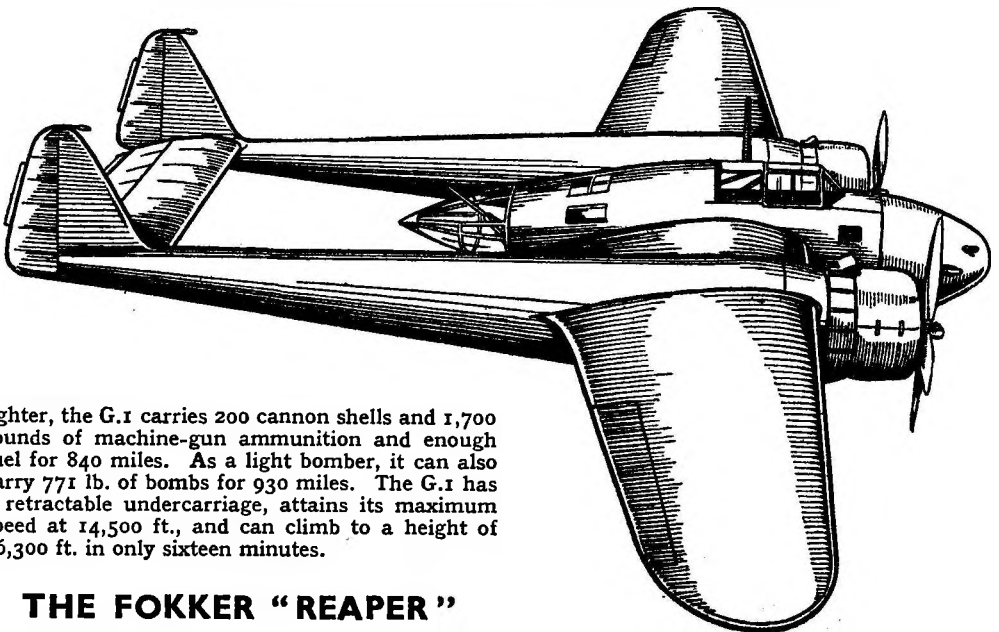

fighter, the G.I carries 200 cannon shells and 1,700 rounds of machine-gun ammunition and enough fuel for 840 miles. As a light bomber, it can also carry 771 lb. of bombs for 930 miles. The G.I has a retractable undercarriage, attains its maximum speed at 14,500 ft., and can climb to a height of 26,300 ft. in only sixteen minutes.

THE FOKKER "REAPER"

—Described and Illustrated by A. C. LEVERINGTON

THE FOKKER D.21 FIGHTER

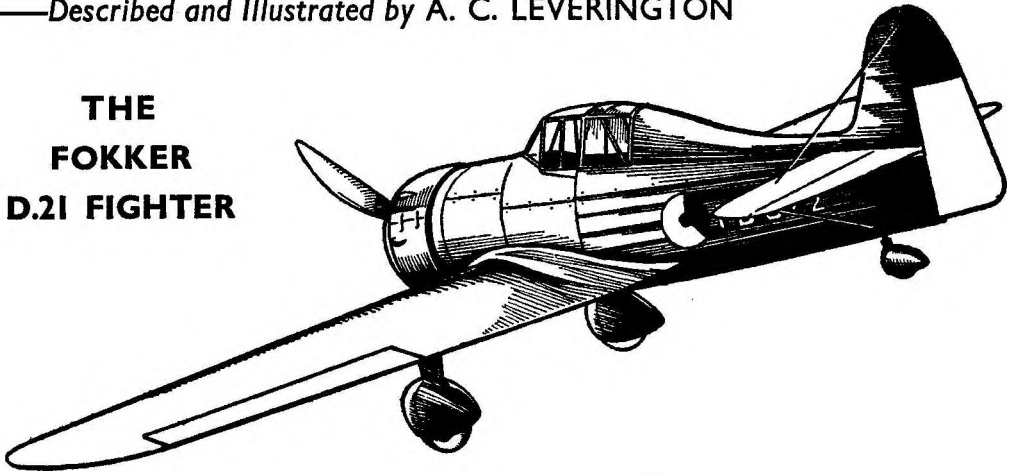

LESS revolutionary in design than the twin-tailed Fokker G.1 is the latest Fokker single-seater fighter, the D.21, lineal descendant of the famous D.7 of the Great War. Following the lines of the latest British practice, the D.21 is a low-wing monoplane in which the pilot is accommodated in a glass-enclosed and heated cockpit. Fitted with a supercharged Bristol Mercury engine

developing 645 h.p. at 15,500 ft., the Fokker D.21 has a top speed of approximately 250 m.p.h., and is likely to be adopted by the Dutch Air Force.

Armament comprises two or more Madsen 7.9 mm. machine-guns and, though the undercarriage is fixed, its highly efficient streamlining offers small wind resistance.

THE U.S. GRUMMAN NAVY FIGHTER

DESPITE its bulky, pot-bellied appearance, the Grumman F2F-1 is the United States Naval Air Service's fastest fighter. Primarily intended for use on aircraft-carriers, it has the low landing speed for a modern fighter of 65 miles an hour, and is fitted with a 14-cylinder 650 h.p. Twin Wasp engine. Cruising speed is stated to be as high as 248 m.p.h. and armament comprises two 30-calibre machine-guns firing through grooves on the top side of the fuselage.

The tail wheel and undercarriage can be retracted when in flight, the landing wheels disappearing into

cavities on either side of the fuselage. The pilot is situated well abaft the wings to give him the widest possible field of view and, when closed, a sliding glass hatch over his cockpit completes the excellent streamline shape of the fuselage. Principal approximate dimensions are span 27 ft., height (in flying position) 10 ft. 6 in., length 22 ft.

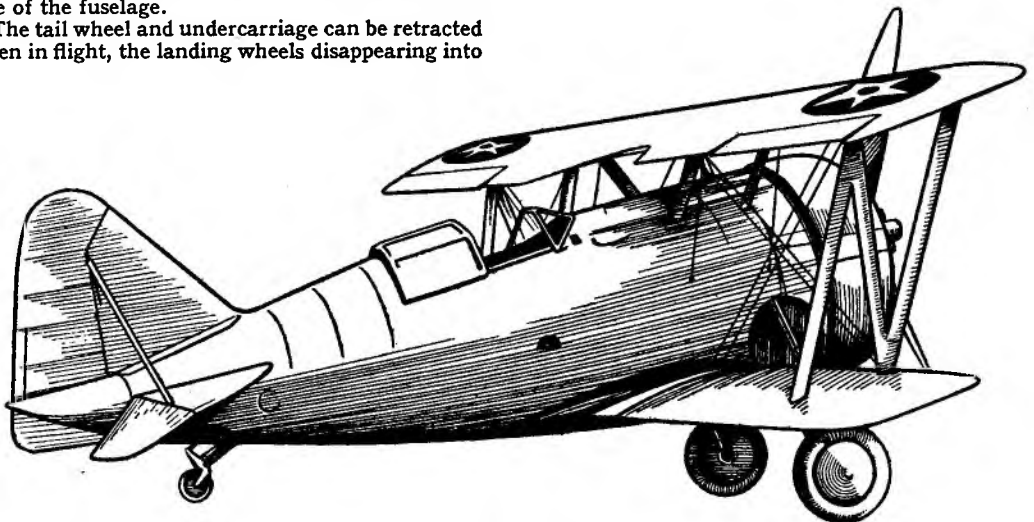

HAWK OF ALLAH

In a Fighter snatched from the Very Hands of the Royal Air Force, Yakub Khan, the Hawk of Allah, Launched the Slashing Raid that was to Set the North-West Frontier Ablaze with Revolt

By LESLIE THOMPSON

CHAPTER I

Revolt on the Frontier

WITH a puzzled frown the Squadron Leader pulled a battered pipe from his pocket and proceeded to fill it. As he did so he was turning over in his mind the information he had just heard, and when he had lit the pipe to his satisfaction he leaned back and shot a question at the man lounging on the other side of the table.

"What's it all about, Barnes? All I'm told is to establish my squadron on this temporary 'drome, two hundred miles north of Peshawar, bang in the middle of the rainy season. Ostensibly we're here to put down sporadic raids by the Datta Khel Wazirs, but privately I'm told to hold myself in readiness to carry out any special job you may require done. Mind you, I'm not kicking against that; you Political Officers know more about the Frontier than we ever will, but what's the big idea?"

The Political Officer sat up. "The big idea is this, Shelton," he said. "You've no doubt heard of Yakub Khan?"

"Who hasn't?"

"Exactly, who hasn't? And that's just what the gentleman wants people to say. He held up the Field Pay Officer at Parachinar last March and got away with 30,000 rupees. He raided Tank in the summer and cleaned out the bazaars. His little visit to Bannu cost the Punjabis fifteen rifles, and so the tale goes on. He's building up a reputation for himself on the Border that is going to cost the Government a whole heap of

trouble one of these days, and frankly, Shelton, H.Q. are worried about him. With the Far East in its present state of unrest we simply can't afford a big blaze on the Frontier. I've had orders to check Yakub Khan at all costs, and as your 'planes are about the most mobile vehicles yet invented you've been sent up here to co-operate."

"I see," responded the Squadron Leader. "And what sort of fellow is this Yakub Khan?"

"About twenty-five, educated at Lahore University and Cambridge; hockey blue, if you remember, and a member of the 'Varsity training squadron. He applied to join your lot but they turned him down—don't know why the Indian Government can't form a native squadron and absorb these young firebrands—keep 'em out of mischief. At any rate, he turned up on the Border about eighteen months ago and has been a confounded nuisance ever since. Now the tribes are solid for him."

"So he's keen on flying, eh?" Shelton remarked. "Too bad he hasn't a 'plane, we might get him where we want him then."

THERE was a long silence, broken at last by the R.A.F. officer, who jumped up suddenly and thumped the table.

"I've got it, Barnes!" he cried excitedly. "We'll give him a 'plane."

Startled out of his usual calm, Barnes looked at him in amazement.

"Sure. Why not give him the squadron and be done with it?" he remarked dryly.

Shelton grinned and sat down again.

HAWK OF ALLAH

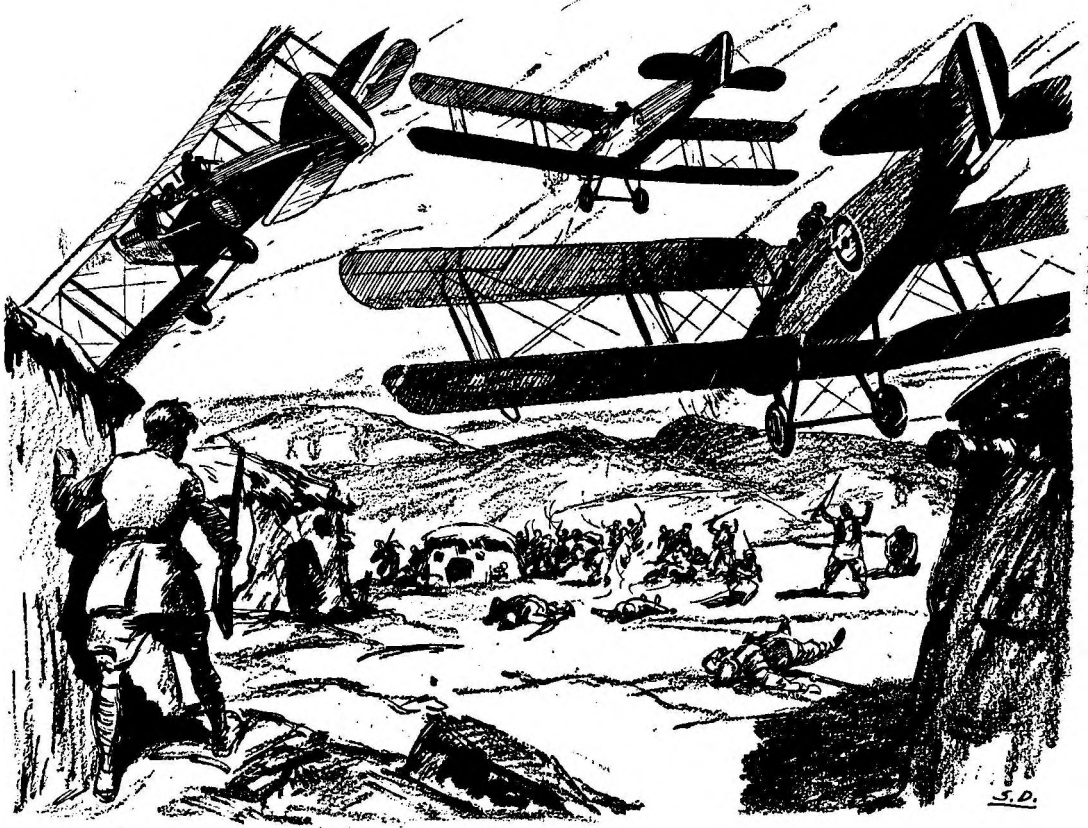

Three Bristols came roaring low over the village looking for trouble

“You think I’m mad? Well, listen,” and leaning forward he rapidly outlined the plan he had in mind for the capture of Yakub Khan. As he finished, the Political Officer shook his head slowly.

“Damn good idea, Shelton, but too risky. It means that someone’s got to put their head right in the lion’s mouth.”

“I can do that part,” urged the Squadron Leader. “There’s hardly any risk if I carry a ransom chit.”

“Can’t be done, old man,” the Political Officer objected. “I tell you Yakub Khan is nobody’s fool, and if the C.O. of a squadron—and you can bet your life he has you taped by now—plants himself down in his village with a perfectly good Bristol Fighter, he’ll smell a large-sized rat. No, if it was ever attempted it would have to be done by one of the pilots.”

Shelton pondered a moment and then rose to his feet.

“All right, Barnes,” he said, “I’ll think it over. By the way, where does this desperado hang out?”

“According to the latest report he’s at a village called Arakhai, about fifty miles north-west of here. But I shouldn’t go calling on him—there’re some sixty or more tribesmen with him, all well armed and just spoiling for a fight.”

“What’s the ground like round the village?” asked Shelton casually.

“Oh, fairly level around the village, runs up to some fair-sized hills about a mile away,” Barnes replied, collecting his hat. “Well, I must be off now; see you to-morrow at the same time, and in the meantime none of your deeds of derring-do. We’ll get the chap all right one of these days, don’t you worry.”

“Righto, Barnes,” answered Shelton, but, as he gazed at the Political Officer’s retreating back, he grinned.

“Yet somehow I wouldn’t be at all

AIR STORIES

surprised if one of my pilots lost his way this afternoon," he told himself as, deep in thought, he picked his way through the tents towards the mess.

CHAPTER II

The Bait takes Wings

WITH a sinking feeling in the pit of his stomach, "Jammy" Chilvers taxied the Bristol Fighter out and turned into the wind. With a last wave to the small knot of pilots over by the Bessoneau hangars he opened the throttle of the Rolls, and with a thunderous roar the 'plane gathered speed, rose quickly into the air and was soon lost to view in the grey mist.

Jammy went straight up to a thousand feet, just below the level of the lowest clouds, and then banking round, he headed away to the north-west. The 'plane trembled and bucked in the disturbed air and, as it roared through the ragged cloud streamers which from time to time enveloped the machine in a cold and swirling mist, Jammy began to feel decidedly uncomfortable.

"Brrr," he grumbled, shivering. "Might have picked a better day for making a blasted fool of myself. Can't see damn all." Easing the stick forward he nosed down a couple of hundred feet, and after peering at the ground for a few moments he picked up a river in full spate.

"Ah!" he muttered in relief. "There's the Jumni—have to head over a bit."

As the 'plane steadied on its new course, weather conditions seemed to be getting worse. Black, angry-looking clouds were scudding rapidly past, wrapping the 'plane in a blanket of clammy moisture, and they had hardly won clear of a large area of this grey wet mist when a flurry of blinding rain swept down on them.

Jammy groaned afresh and, pushing his steaming goggles up, strained his eyes in an effort to pierce the driving rain. It was hopeless. The ground below was blotted out, and crouching lower in the cockpit he drew what comfort he could

from the healthy roar of his 350 h.p. Rolls, and hoped for the best. After a few minutes they ran through the squall, and peering ahead he caught sight of a few scattered huts—Arakhai! Again he felt a tremor in the region of his belt, but gritting his teeth, he searched out a level stretch of land and, throttling back, swished down to his landing. Slipping the Bristol round into the wind he touched wheels and skid down together in a neat three-pointer and allowed the machine to rumble and bump over the uneven surface until it came to a stop.

"Well, here we are!" he exclaimed, gazing at the silent huts. "No sign of the Mayor and Corporation. Better go and look for 'em."

His feet had hardly touched the ground when, with a chorus of fierce yells, a crowd of tribesmen burst through between the huts and rushed towards him. They were Wazirs and as the mob crowded round the 'plane, talking excitedly in rapid Pushtu, they fingered their knives suggestively and glared at the pilot.

Jammy glanced round the ring of sinister faces and decided it was time to say something.

"Er . . . *Kitna pice tumara churies?*" ("How much for your knives?") he inquired in halting Hindustani.

A stir went rippling round the watchful tribesmen, and one or two were attempting a threatening advance when a quick order rang out. They shuffled back to allow a young Wazir to saunter into the middle of the ring and bow to the airman.

"Welcome to Arakhai," the young native said in fluent English. "I trust my men haven't overwhelmed you with their welcome; they see so few strangers, you know, it makes them a little hasty."

As the polished drawl ceased, Jammy gazed open-mouthed at the young tribesman. Dressed in white loose-flowing trousers and a sheepskin *poshteen*, there was nothing to distinguish him from the crowd of others, except perhaps an air of easy authority that sat lightly on his jaunty shoulders.

"Who the devil are you?" Jammy managed to splutter.

HAWK OF ALLAH

The native bowed again.

"I am Yakub Khan," he answered quietly.

JAMMY gulped with astonishment. So this youthful, self-possessed Wazir was the notorious outlaw around whose name the Border tribes had woven such tales of courage, resource and daring. This was the beardless boy who was freely spoken of as the chosen of Allah, the destined leader on the great day when the Border would flame from end to end and all men would unite to drive the hated Feranghi from their beloved hills.

"But I thought Yakub Khan would be a big hefty merchant, with a red beard and a belt full of knives," gasped Jammy. The outlaw smiled, and turned to examine the 'plane.

"Ah! A Bristol Fighter, I see," he remarked. "Why did you land here—engine trouble?"

"No," growled the pilot. "Lost my way in that confounded rain storm."

"Lucky for me you did," replied Yakub Khan, climbing up to the front cockpit. "There're still a few minutes of daylight left. I think I'll try a flip."

Calling for two large stones to act as chocks, he was about to climb into the cockpit when Jammy strode forward in well-simulated wrath.

"Here! You can't do that. Come out of that 'plane."

"You forget yourself," said the outlaw in a tone of reproof. "Perhaps the loss of an ear or a finger or two will help you to remember that I give orders here. Now get round in front and swing that prop. like a good fellow."

Despite the bantering tone, Jammy caught the latent ferocity and studied insolence of the man, and his right hand itched for one good smack at his jaw. But, remembering his job, he pulled himself together and, as if awed by the threat, he slouched despondently to the front of the 'plane and, after sucking in, swung the propeller down with all his strength. Still warm from its previous flight, the engine started up with a throaty roar, causing the assembled Wazirs to stampede in sudden panic.

After testing the revs. Yakub Khan ordered the stones away, and taxying out into the wind took-off with practised ease.

As the 'plane rose and circled the village Jammy watched intently, saw it gain height, shoot up in an Immelmann, then fall into a quick spin. As the Bristol whirled earthwards there were loud cries of alarm from the tribesmen, cries which soon turned to yells of approval as the 'plane flattened out and came down for a perfect landing.

"Um," murmured Jammy thoughtfully. "The lad can certainly handle a kite."

Taxying slowly back to the waiting group, Yakub Khan switched off and climbed down. Then, after detailing some of the men to mount guard over the 'plane, he turned to the silent pilot.

"Thank you, my friend, for the gift of this 'plane—it is the one thing that I've missed. But the ammunition I cannot accept. Your Government does not allow us such dangerous playthings, you know. I will return it to your camp in the morning."

With a mocking glance at Jammy he barked out a sharp order, the tribesmen closed in and the party moved off with the R.A.F. officer in the centre. On reaching the village the Wazirs scattered, leaving four men to guard the prisoner, and these Yakub Khan led over to one of the smaller huts and motioned them inside.

"Not palatial, I'm afraid," he said to Jammy with an air of apology. "But at least it will provide shelter from the weather. Take the inner room, will you, there's wood there and food will be along presently. Oh, and by the way, I rather advise you not to give any trouble," and with a significant stare at the guards he stepped outside and shut the door.

Feeling cold and wet, Jammy soon had a cheerful blaze going in the corner of the room, and crouching over this and enjoying the grateful warmth stealing through his chilled body he felt that the worst part was over. The C.O.'s scheme was going like clockwork. Yakub Khan

AIR STORIES

had swallowed the bait, hook, line and sinker, and to-morrow he'd be pulled in and landed. Then what? As Jammy idly pondered the chances of his escape, the door was kicked open and Yakub Khan walked in with a steaming dish and a flat loaf.

"You'll have to manage with your fingers, I'm afraid," he said, handing them down. "But it's considered quite the thing in these parts."

Too hungry to worry about the niceties, Jammy grabbed the food and with the aid of the bread managed to make a good meal. Satisfied at last, he wiped his mouth on the sleeve of his Sidcot suit, lighted a cigarette and leaned back against the wall puffing luxuriously.

"As an educated man," he asked suddenly, "why on earth do you live a life like this?"

The outlaw gazed at the fire, and his eyes smouldered.

"To men of my colour most of the adventurous walks in life are closed, however educated they are. Here I can get the sort of life I want. One dies of many things on the Border, but never of boredom. The rifle is law and a man takes what he wants if he can."

"So I noticed," murmured Jammy, "when you pinched my 'plane just now."

Yakub Khan rose to his feet and looked down at his captive.

"Yes, my friend, and to-morrow I shall want your flying suit," he said, and with a muttered order to the guard, left the hut.

Left alone, Jammy finished his smoke, put some wood on the fire and lay down to sleep.

IT seemed but a few minutes later when Jammy was aroused by a violent shaking and opened his eyes to find the outlaw bending over him.

"Come, I want your flying kit, it is nearly dawn," he said.

With ill-grace Jammy wriggled out of the Sidcot suit and stood shivering in the keen air. Quickly the outlaw slipped into the borrowed gear, then handed over his sheepskin coat to the airman.

"Put that on," he said, "and give me a hand to start the engine."

As he stepped outside the hut into the pitch darkness Jammy felt the dawn wind, and throwing back his head gulped down great lungfuls of the sweet, clean air, fresh and pure after the stuffy confines of the small room.

In silence they stumbled over the ground until a hoarse cry from the darkness ahead challenged them. Giving a curt reply, Yakub Khan strode up to the 'plane and climbed into the front seat.

With a dead cold engine to start, Jammy had to swing the propeller many times before it finally caught and shattered the brooding silence by a thunderous roar that was quickly tamed to a throaty gurgle as the outlaw throttled down to warm up. Satisfied at last, he waved the stone chocks away, and opening up the engine was quickly swallowed by the darkness as he shot away on his take-off. A few moments later the roar of his engine had died away in the distance and Jammy gave a sigh of relief.

"Well, the money's in the air now," he muttered to himself as the guards closed round him and shepherded him back to the hut.

CHAPTER III

A Trap is Sprung

LIKE creatures of the night surprised by the first hint of dawn, the four 'planes sped across the 'drome and climbed out of the darkness towards the lightening East. As the steady drone of their progress gradually diminished the men who had sped them on their early morning errand broke into swift action. Collecting all the loose gear, they quickly stowed it in a Bessoneau hangar and, lacing up the fronts of the "empties," melted away, leaving the 'drome deserted and, to the casual eye, as yet undisturbed from its night's peace.

As the machines gained altitude the C.O. headed the formation west to avoid a possible silhouette of his flight against

HAWK OF ALLAH

the lightening eastern sky. The precaution reminded him of dawn patrols during the old days in France, when neglected precautions were usually paid for by a swift stream of lead from a chattering Spandau playing the prelude to an empty seat in the mess. Smiling grimly at the memories evoked, he settled down to the business in hand.

That Yakub Khan would come he had no doubt, and that he would choose the early dawn for his raid on the sleeping camp he was equally confident. He had put himself in the outlaw's place and argued that the soundest plan would be a high approach, then a long glide with the engine throttled back so as not to alarm the camp. It was with this probability in mind that the C.O. had ordered Ross and Walker to patrol at three thousand feet, while he and Rickaby went up to seven thousand feet.

"Can't see any snags," he muttered. "Fellow's bound to come over, and he'll have a light background showing him up. If he makes a detour, Ross and Walker will spot him attacking the camp."

Glancing at his altimeter, he waved his arm and as the two rear machines banked round he eased back the stick and went up in a steady climb with the other 'plane keeping formation just off his starboard wing-tip. At seven thousand feet the C.O. flattened out, reduced his air speed to some seventy-five miles an hour, and headed north-west, straining his eyes ahead for the fast moving speck which would tell him that his trap was sprung.

Then, as one slow minute followed another, a disturbing thought crept into his mind.

Suppose Yakub Khan didn't come! Suppose he suspected a trap! A Bristol Fighter given away and one of his best pilots handed over to the tribes! There would be a Court of Inquiry, of course, then what! Dismissed the service, probably.

It was a gloomy prospect. Then the C.O. remembered Jammy, and a grim expression settled on his face.

"By God!" he muttered savagely.

"He took on a rotten job, and I'll get him away if I have to . . ."

What he would have done is problematical for at that moment a smack on the shoulder made him turn quickly in his seat, and a smile of unholy joy chased the grim expression from his features as his observer pointed out a dim shape flitting earthwards, almost at their rear.

"That's him!" yelled the C.O., and slamming open his throttle he banked round and screamed down in a breath-taking power dive that strained every bolt in the "Brisfit."

ALL unconscious of his escort, the outlaw was now slipping his machine quietly down towards the sleeping camp, intent on another of those swift, slashing raids that had made his name a byword on the Frontier. This time, too, there was an added zest in the venture in using a weapon snatched from the very hands of the enemy.

Eyeing the distant camp taking shape between his port wings, he allowed his mind to dwell on his coming triumph. What a tale would run from village to village! How the men would laugh in their beards at his latest exploit! Yakub Khan, the Hawk of Allah! And while their enthusiasm was white hot he would strike, unite the tribes into one mighty host and pour them over the Border in an overwhelming horde! With Afghanistan a seething mass of unrest, and Russia behind them ever watchful for an opportunity, one sensational success would see the British lion struggling in its death throes.

A faint roar rapidly gaining in volume banished the glowing picture from his mind, and he turned his head swiftly to stare wide-eyed at two 'planes that came racing down to cut him off. For a long second he was frozen immobile by this totally unexpected attack, then, with the swiftness of a striking cobra, he flashed his throttle wide open, continued his dive to gain maximum speed, and, as the leading Bristol swung round on his tail, he zoomed up in a fierce climbing turn. There, dead ahead, was exactly what he had expected: Rickaby roaring down in

AIR STORIES

the wake of his leader. Aiming just in front of the Bristol's nose, Yakub Khan pressed the trip lever. There was a short angry chatter from the Vickers, and as the 'plane continued its headlong dive into the snarl of lead its propeller flew into fragments. The stricken Bristol staggered under the blow, and as the engine screamed and juddered with frightening violence Rickaby switched off, banked out of the fray and swung down to the safety of the 'drome.

The Hawk had drawn first blood.

But the chant of his Vickers was dumb after that first short, destructive burst, and the hunted man's heart leapt with a sudden alarm—a jamb!

"By the Holy Prophet," he muttered through clenched teeth. "What cursed luck."

His hand shot out to the now useless gun, when a sudden vicious stutter broke out behind him and a spurt of chips flew from an interplane strut. He flung a swift glance behind him, saw a Bristol Fighter close on his tail, and, kicking his 'plane into a spin, he pulled out low down and fled north.

But Shelton had sent too many Huns crashing to earth to be deceived by a trick like that, and Yakub Khan, crouching low in his cockpit, heard again that menacing dirge from the gun of his pursuer and saw a row of holes creeping in from his port wing-tip towards his fuselage.

Caught in a trap from which there seemed no escape, and with a useless gun, a desperate expedient flashed through his brain. He would gain height and charge the other 'plane with his undercarriage. Pushing the stick well forward, he plunged down in a dive, followed by the relentless Bristol. Then, suddenly leaning back, he pulled the stick well into his stomach. The machine soared upwards in a loop, and as it came over on its back he did a quick half roll and banked round, only to hear the remorseless fire from Shelton's gun burst out behind him. It was a final warning that the game was up, that his life was in the hands of this man who was keeping his Bristol tied to his tail. Yakub Khan cursed his impotence; the next move might mean

a burst of lead that would rip through the fabric of the 'plane and tear into his body from behind to send him crashing, perhaps in flames, to the earth below. It was not the death he desired, and he flung up his hands in token of surrender.

A red light curved away from Shelton's machine, and in response two Bristols swung up from the west and ranged themselves one on either side of the raider, the thin, sinister barrels of their rear Lewis guns pointed ready to unleash a hail of lead at the first treacherous move. But their deadly muzzles remained dumb; the Hawk of Allah, it seemed, was tamed at last.

Landing first, Shelton waited for the other two 'planes to land, and as Yakub Khan climbed stiffly to the ground he strode forward, eyeing the outlaw curiously.

"So you fell into our little trap, Yakub Khan?"

"You mean that this was all planned?" was the incredulous reply.

"Certainly," replied Shelton, grinning. "Even the jammed Vickers—though I must compliment you on the damage you managed to do with only fifteen rounds. Too near to be pleasant, eh, Rickaby?"

"Damn good shooting," grunted Rickaby. "Right-angled deflection, Micky Mannoek's favourite."

"Aren't you forgetting that I still hold your pilot prisoner?" broke in Yakub Khan, with a sneer. "Things might be a little unpleasant for him if I do not return."

"We'll take care of that," growled the C.O., turning to the escort that had now arrived. "Sergeant, put this man in an empty tent in the officers' lines. Three sentries on duty round the tent, and change 'em every hour. If he attempts to escape shoot to kill."

"Very good, sir," said the sergeant, saluting, and as the outlaw was hustled away the C.O. swung round to the Adjutant.

"All officers in the mess tent *ek dum*, we've got to get Chilvers out of it as quickly as we can. I can talk as we have breakfast."

HAWK OF ALLAH

CHAPTER IV

Raiding the Raiders

FLIGHT LIEUTENANT "Jammy" Chilvers stopped his restless pacing and looked at his watch.

"Seven-thirty!" he muttered. "Time the Old Man was here."

To soothe his jumpy nerves he lit a cigarette, and for the hundredth time went over the plan for his escape. The C.O. would fly back as if it was Yakub Khan returning, and by landing about a mile away from the village would hope to draw the tribesmen well away from the huts. By the time they had reached the 'plane and forced him to take-off again, the supporting 'planes would be down to keep them on the run and so busy saving their own skins that they would have no time to worry about what was happening to their prisoner. That was the idea; the practice, as Jammy was well aware, was in the lap of the gods.

Glancing at the four guards huddled up over the fire, he knew that his successful getaway depended entirely upon them. If they all stuck to the hut when the 'plane landed he stood an excellent chance of being shot when the trouble started. But, knowing their excitable natures, he thought it more probable that some of them, at least, would dash away, and on this probability his life depended.

Slowly the leaden-winged minutes crept by, and at last his practised ear caught the low insistent hum of an aero engine, growing rapidly louder. Soon the guards, too, had heard it, and jumping to their feet they rushed out of the hut, yelling with delight as the 'plane swept low over the village.

"Yakub Khan! Hai, hai! Yakub Khan!"

Banking round, the 'plane dropped low, and as it disappeared from view behind the huts the Wazirs streamed down through the village, shouting and laughing as they prepared to welcome their triumphant leader. And as, without a moment's hesitation, three of his guards joined the hurrying throng, Jammy sighed with relief.

"Just what the doctor ordered," he murmured thankfully. "Pity old Sinbad here doesn't follow suit."

But the remaining guard, tired of screaming threats and curses after his disappearing comrades, spat angrily and squatted down by the door, fingering his rifle in a manner that more than hinted he would like to use it on his charge.

"All right, old son," said the airman amiably. "Nobody's going to hurt you . . . yet," he added under his breath.

The Wazir snarled with rage and, drawing his hand across his throat suggestively, was starting off on a long tirade in Pushtu when suddenly a high-pitched whine cut through the silence of the village like a knife, and the words froze on his lips.

Scared out of his wits by this unknown terror, the frightened native caught up the ragged end of his turban and nervously shielded his eyes as he muttered a frantic prayer. At the same moment Jammy tensed himself for a quick effort. Too often he had heard the "singing" of bracing wires not to know that his comrades were swooping down on the village with their engines just ticking over. Even as he leapt on the crouching guard six engines opened out with a roar that shook the ground, and to the accompaniment of a devil's cacophony from their front guns Jammy fought for his freedom.

SPRAWLING on top of the struggling tribesman, Jammy thrust his left hand up through the tangle of beard and found the Wazir's windpipe. His fingers gripped home and a cry of alarm was strangled quickly into a choked gurgle. Forcing back the native's head, the pilot let fly to the point of the jaw, and the blow went home with all the power he could put behind his right arm. Without a sound the guard fell limp, out to the world. Hurriedly tying his ankles to his wrists with his turban, Jammy grabbed his rifle, collected some rounds from the Wazir's belt, and, stepping through the door, glanced rapidly round.

"All quiet on the eastern front," he

AIR STORIES

panted. "Better see if the Guv'nor's ready to pick me up."

Three Bristols came roaring low over the village looking for trouble, and as their occupants spotted Jammy they waved a frantic greeting. Waving in reply, he doubled through the huts and crouched low against a wall, peering out across the level ground in front of the village.

The four other 'planes were playing havoc with the panic-stricken tribesmen who, caught on the open ground and with a constant stream of lead kicking up spurts of dust at their heels, could only keep running blindly away. Back and forth above the mob roared the Bristols, zooming and diving, while their observers plied their rear Lewis guns in well-directed bursts that made the laggards accelerate with a most undignified rapidity.

"The lads seem to be enjoying themselves," chuckled Jammy, then turned to peer intently at a 'plane that shot up over the distant hills and came hurtling on towards the village.

"Now we shan't be long," he exulted, recognising the leader's streamers on the approaching 'plane. "Good old ——"

"Spang !"

A bullet bit viciously into the mud wall behind his head, and as the dust spurted up in a cloud he dropped flat, straining his eyes along the ground.

"Must have come from those rocks over there," he thought. "Better lie doggo a bit and kid him he's scored a bull—feel as big as an elephant, though."

Keeping perfectly still and expecting every second to hear the sharp crack of a Snider, he lay watching the group of rocks in the near distance. A 'plane roared overhead, and as it turned out of sight over the huts a white-turbaned head rose slowly into view and a Wazir, crouching low, ran for the shelter of the huts. Gaining the wall, he began to creep slowly along in the direction of the hut where Jammy had been held prisoner. Again the 'plane roared round, looking for signs of movement among the huts, and instantly the tribesman flattened himself against the *mutti* wall. In a flash Jammy slewed round on the ground and,

whipping up his rifle, fired. Taking an uncertain step forward, the native hesitated, then pitched headlong on his face and lay still.

"Better you than me," murmured Jammy, wiping the sweat from his brow. Then, he scrambled to his feet and darted towards the now landing 'plane. Hardly waiting for it to pull up, he grabbed hold of the fuselage and clambered into the rear cockpit.

"Good work, Jammy !" roared the C.O. "Damn' pleased to see you ! Had any trouble ?"

"All I wanted," replied Jammy, rubbing his knuckles. "What about opening that throttle, I've had about enough of this place."

JAMMY'S welcome back to the squadron would have done credit to a victorious Roman general returning from the conquest of Britain, and he afterwards confessed that he would much rather spend a week with the Wazirs than go through it again. But go through it he had to until at last he was rescued by his brother officers and escorted to the mess.

"I suppose you know, Jammy, that I'm putting you in for a decoration," said the C.O., walking by his side.

"Thank you, sir," stammered Jammy. "My 'Mutt and Jeff'* do look rather lonely, don't they ?"

The C.O. grinned.

"By Jove ! that reminds me ! We'll invite our prisoner to dine with us as we used to do in France. And what about having old Barnes there, too ?"

A mischievous twinkle appeared in Jammy's eyes, and he almost doubled up with mirth.

"I say, sir," he giggled helplessly, "Colonel Barnes doesn't know we've captured Yakub Khan. Don't tell him. Sit him next to him at dinner."

The C.O. exploded.

"Jove ! It'll cost me a rough ten minutes afterwards, but I'll do it. It ought to be priceless."

It was.

* "Mutt and Jeff"—Nicknames of the General Service and Victory Medals awarded to all British combatants with six months' Great War service.

SKY GUNS of TO-DAY

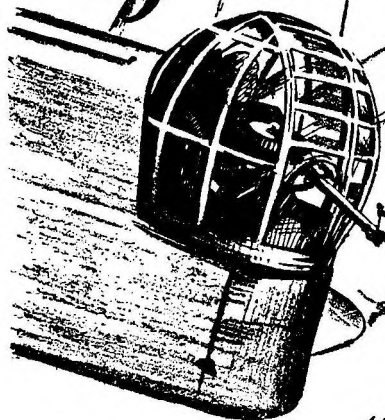

By
"Armourer Sergeant"

**Secrets of Shell-Firing Cannons and Machine-Gun Turrets
are Disclosed in This Survey of Modern Air Fighting's
Most Formidable Weapons**

SINCE the Great War the subject of aircraft armament has been of such a "hush-hush" nature and so hedged about by official secrecy regulations that the public knows a great deal more about modern military aircraft than about the guns with which they are fitted. Enough has, however, been revealed to show that within recent years there have been momentous advances in the development of aircraft ordnance which, in turn, have brought about a profound change in air fighting tactics.

Outstanding among these advances has been the great improvement effected in the accuracy of gunfire in multi-seat aircraft by the use of enclosed, power-operated gun turrets. No less important has been the amplification of fire power in single-seaters by elaborate installations of machine-guns or small-bore cannons, or both. There is no difference of opinion as to the high value of the enclosed gun turret which, in various

forms, is now being adopted by all the leading Air Powers, but there are two very distinct schools of thought as regards the value of the cannon or shell-firing gun.

The weapon is not, of course, by any means a new one, having been first used in aerial warfare as long ago as 1917, but its recent revival in a highly-developed form has been claimed by its protagonists as revolutionising all former conceptions of aerial warfare. They claim for it, with truth, that it has a far greater destructive power per shot than any machine-gun invented, that it is effective at much longer range, and that its shell provides the only sure means of destroying a modern all-metal military aeroplane which, provided no vital part is hit, can be almost riddled with machine-gun bullets without putting it out of action.

In reply to these claims the opposite school of thought, who regard the cannon as only a passing fashion of no permanent military value, maintain that

AIR STORIES

an aeroplane mounting, say, eight high-speed machine-guns can discharge in a given period a far greater number of projectiles than any cannon-equipped machine. Further, they argue that in the high-speed "tip-and-run" fighting tactics that will be the practice in any future war, the ability to envelop your opponent in a veritable spray of leaden death at close quarters will be far more effective than sitting out of range and taking pot-shots with a cannon at an enemy who is probably travelling at well over 300 miles an hour.

Nevertheless, the cult of the cannon is steadily gaining ground on both sides of the Atlantic, and to-day Great Britain and Germany are alone among the great Air Powers of the world in having almost completely neglected the weapon. Other air services are adopting cannon-fitted aircraft as standard equipment, but the Royal Air Force, in even its very latest types of fighters, prefers to rely upon a battery of machine-guns—and probably only another war could prove whether our policy is right or wrong.

Machine-Gun Developments

SECRECY restrictions do not permit of any description being given of the latest types of machine-guns with which the R.A.F. are now experimenting, but since they are apparently preferred to cannons, it is not unreasonable to assume that they show very great advances on all previous types of machine-guns. One of the most promising of the new guns is believed to be the Vickers-Berthier .303 high-speed gun, a number of which were recently adopted by the Portuguese Navy as the observer armament for their new fleet of Blackburn Shark torpedo-bombers. Another gun in which the Air Ministry are interested is the new Bren gun, made by the Czechoslovak Arms Manufacturing Co. of Brno, Czechoslovakia, and recently adopted by the War Office as a replacement of the Lewis for infantry and armoured car use. A modernised and much improved version of the Lewis gun, the Bren incorporates a gas cylinder, piston and recoil spring,

and if its feed system can be re-designed so that the magazine will carry about 100 rounds instead of its present 30, it is quite likely to be adopted as a "free" gun by the R.A.F. The American Browning is yet another small light machine-gun which has been extensively tried out in the R.A.F. of late with very satisfactory results.

Meanwhile, however, the machine-guns generally used in the R.A.F. to-day are still the Vickers and Lewis guns of Great War fame, modified in minor details and brought up to date. The Vickers is still the standard type of fixed gun and is essentially a pilot's weapon, which is rigidly attached to the aircraft and trained by manoeuvring the machine to which it is fixed.

A common installation on a fighter aircraft is a pair of Vickers guns mounted in the fuselage and firing through the arc swept by the airscrew. Such guns would, of course, be fitted with the improved form of Constantinesco synchronising gear now used in the R.A.F., or, if the engine was of the high-speed radial type, a new form of gun gear developed by the Bristol Company would probably be employed. Very little is known about this new gear other than the fact that it has proved very successful in service, and incorporates a governor which automatically changes the timing of the gun as the engine speed increases.

The most popular British method of mounting the two Vickers guns on a fighter is to instal them one on either side of the fuselage or beneath the upper engine cowling with their breeches inside the cockpit and their muzzles projecting into troughs let into the cowling. In this position the loading handles are easily accessible to the pilot, the lids over the gun mechanisms may be opened and the entire lock replaced in flight if necessary. Similarly, the feed chutes leading from the ammunition boxes may be opened and stoppages easily cleared. R.A.F. practice is for the ammunition to be carried in two metal boxes which feed to the right- and left-hand guns through necks, and about 600 rounds are usually provided for each gun.

THE FIGHTER PILOT'S POINT OF VIEW

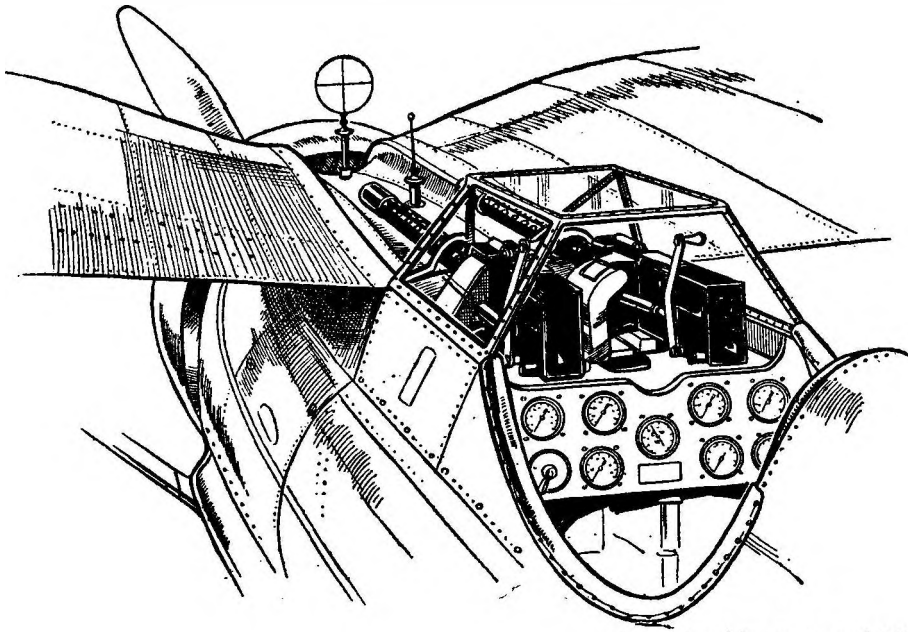

[Reproduced by courtesy of "Flight."]

The cockpit of a Polish P.Z.L. "gull-wing" fighter showing the accessibly-mounted twin machine-guns. Note the loading handles, side chutes for spent cartridges and reversed "bead and ring" centre sight

Where more than two fixed forward-firing guns are required, others may be mounted as "outboard" guns in the wing-roots or in the fairing of the undercarriage. In such cases these guns are often fired by electric solenoid trigger motors connected, through the battery circuit, to the trigger mounted on the pilot's "joystick." Their loading handles are operated through remote control, and their ammunition boxes must be made long and flat so as not to interfere with the contour of the wing.

The advantages of this outboard installation are that, as the gun is unsynchronised, its rate of fire is unimpeded by the speed of the engine, while the pilot's cockpit can be kept clear of the guns, ammunition boxes and synchronising gear reservoir. The disadvantage is that, the breech being inaccessible, the pilot cannot clear any stoppage that may occur. As outboard guns are, however, usually fitted only in aircraft provided with a battery of guns, the failure of one or even two is not of vital importance.

A typical example of the multi-gun

fighter in the R.A.F. is the Gloster Gladiator, which carries two synchronised Vickers in the sides of the fuselage and two outboard guns mounted in the wings. In such installations the lines of fire of all the guns converge at a predetermined point directly ahead of the machine. The pilot has then only to train the nose of his machine on a target to bring his entire battery to bear in a deadly cone of fire. Normally, the converging point of fire, usually some 200 yards directly ahead of the machine, is fixed, and once set on the ground cannot be varied in flight. On the Continent, however, a very ingenious system has lately been evolved whereby on a machine fitted with two pairs of guns the converging point of the lines of fire of each pair may be varied during flight in their distance from the machine from 120 yards to infinity.

R.A.F. Fixed Guns

THE Vickers guns used in the R.A.F. to-day as standard armament equipment are modified versions of the Vickers

AIR STORIES

Class "E" pattern. The working principle of this gun has already been fully described in an earlier article,* and it may suffice here to record that it is of the "barrel recoiling" type and consists of three main parts, the feed mechanism, the recoiling parts and the non-recoiling parts. It is automatically operated by two forces: the explosion of the charge in the cartridge which forces the recoiling parts backwards, and a strong spiral spring which carries them forward. After a round has been fired, the empty cartridge is automatically extracted and ejected, a live cartridge is placed in firing position and a fresh round brought into the feed block. The bullets are carried in 250-round belts in which the cartridges themselves are the pins in the links of the belt. As each cartridge feeds into the breech, the link of which it was the pin falls away. On high-speed machines, side scoops or some similar receptacles are provided to collect the empty cartridge cases and links which might otherwise be caught in the slipstream and cause damage to the tail structure. The rate of fire of the Vickers is about 1,000 rounds a minute, and the same .303 calibre bullet as was used in the Great War is still the standard ammunition. Fresh belts can quickly be fitted to the gun, and for this purpose the pilot is provided with a loading handle which enables him to reload without having to pull the belt through the feed block.

MODERN gun-sights show no very marked improvement over those used during the latter part of the War, and the Aldis tube, together with the "ring and bead," are still the standard types of R.A.F. gun-sights. The Aldis sight, often erroneously described as a "telescopic" sight, consists of a tube containing a series of lenses which have neither magnifying nor diminishing properties. It is fitted with a rubber eye-piece and has inside the tube two circles which must be lined up on the target.

On fighter types the Aldis is generally used in conjunction with a "ring and bead" sight mounted parallel to it just in front of the pilot's windscreen and over the centre line of the machine. (See illustration opposite.)

The "ring and bead" sight is made up of two parts, a metal ring with a smaller ring in the centre supported by four radial wires, and a bright red bead mounted directly ahead of the ring. The ring is nearest to the pilot's eye and the bead is so mounted that when it can be seen in the centre of the small ring it indicates the axis of the guns at their predetermined range.

For the R.A.F. observer-gunner, the Lewis remains the standard type of "free" gun, though its freedom of movement has been greatly increased of recent years by the introduction of improved forms of mountings and power-operated turrets. A "gas operated" type of gun, the Lewis is worked by two forces—the pressure of the gas generated by the explosion and a "return" spring. Developed from the heavier and water-cooled "land" type, the air Lewis of to-day fires a .303 calibre bullet and has a rate of fire of about 700 rounds a minute. Ammunition is carried in the same type of 97-round drum that was first introduced into the R.F.C. in July, 1916, and, whilst these are still widely used, there is now a tendency to revert to the smaller drums as being lighter and therefore easier to handle at high speed.

A war-time invention is also the basis of the present type of sight used on the R.A.F. Lewis gun. This is the Norman vane-sight, an ingenious device by means of which it is possible to make allowance for the speed of the aircraft from which the gun is being fired and also for "deflection," the distance that the gun must be aimed ahead of its target to allow for the movement of the enemy machine while the bullet is travelling through the air. In the Norman vane-sight a bead and a vane are mounted on either side of a central rotating pillar and set on gimbals which permit of vertical and lateral movement (see sketch on p. 323).

* See "Guns of the War Days," AIR STORIES, January, 1937.

SKY GUNS OF TO-DAY

The airstream acting on the vane ensures that its axis is always parallel to the line of flight, while the ring-sight, farther back on the barrel, enables the necessary deflection allowance to be made. For a gun-sight that was first invented during the War by an R.F.C. officer, the Norman vane-sight is still remarkably effective, but the increasingly high speeds of modern military aircraft are now rendering it obsolescent. Its successor will undoubtedly be some form of mechanically-operated sight, several of which are now in an advanced stage of development.

High-Speed Gun Mountings

ANOTHER important result of the increase in speed of military aircraft has been the great improvement effected in the design of mountings for free guns. As flying speeds increased, it became more and more difficult for a gunner standing in an open cockpit to manipulate his gun against the force of the airstream. It was found that even when flying level at speeds approaching 200 miles an hour it was as much as the

strongest gunner could do to train a single Lewis against the airstream. At any higher speeds, such as when the machine was diving to the attack, the air pressure was so great as to render the gun virtually immovable. Furthermore, as aircraft performance improved and the ceilings of fighters rose accordingly, it was found that the rarefied air of great heights took heavy toll of a gunner's strength, and that efforts which he could manage easily at ground level were far too exhausting to attempt at 20,000 feet.

The first step towards remedying this was the fitting to a modified form of Scarff ring mounting—the wartime invention of Warrant Officer Scarff, R.N.A.S.—of a wind-balancing device which gave a turning movement equal but opposite to that given by the pressure of the airstream on the gun. This mounting is still extensively used in R.A.F. open-cockpit aircraft, but as air speeds continued to increase, still more efficient mountings were needed. These were soon provided in the form of ingenious “high-speed” gun mountings such as

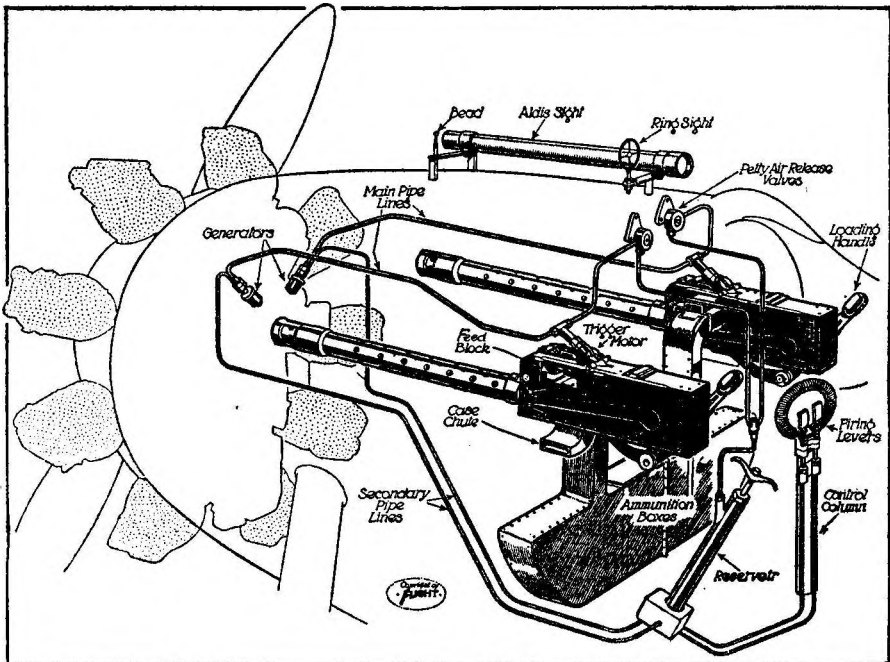

[Reproduced by courtesy of "Flight."]

A diagram showing the installation of a pair of synchronised Vickers guns on a modern radial engine fighter. Note also the two types of gun-sights mounted on the cowling

AIR STORIES

the Hawker, Avro, Vickers-Armstrong and Fairey types—to mention only a few that have appeared in recent years. The Fairey pattern was of particular interest as, apart from the ease with which it enabled the gun to be manipulated, it also made it possible to fire directly astern, vertically upwards and downwards, above and below the tail plane and over the top main plane—advantages not possessed by the ordinary type of ring mounting.

The next step forward was to protect the gunner himself from the force of the airstream, and one of the first British aircraft constructors successfully to achieve this was the Bristol company in their Type 120 day-bomber. In this machine a Scarff ring mounting was fitted low down in the gunner's cockpit and surmounted by a transparent cupola. One section of glass was omitted to allow the gun to protrude, and the entire cupola could easily be rotated for training the gun in any desired direction. Other aircraft constructors soon followed suit, new types of turrets appeared and ingenious devices were soon incorporated for their mechanical rotation. An interesting result of this advent of sheltered gun positions has been a revival in the use of twin-guns on a common mounting—modern successors of the double Lewis of the War days.

A Power-operated Turret

PROBABLY the most advanced type of R.A.F. power-driven gun turret that it is permissible to describe is that fitted to the Boulton Paul Overstrand medium bomber and designed by the constructors of the machine. As fitted in the Overstrand this turret is located in the extreme nose of the fuselage, where it is held in place as an egg might be between finger and thumb (*see illustration opposite*). It consists of a cylinder with domed ends which is covered almost entirely with transparent material. It is mounted at its base in a bearing carried from a bracket built into the front fuselage frame and is supported

further by a special roller bearing that only partly surrounds the upper extremity of the cylindrical body, but which effectively supports the turret against loads in all directions. Within this turret is a pivoted gun arm, carrying a Lewis gun, the barrel of which projects through a vertical slot extending the whole depth of the turret, and allowing the gun to be moved over the entire vertical range. The gunner sits within the turret on a seat supported by an hydraulic ram which is connected to a pair of smaller rams coupled to the elevating gun arm. The two sets of rams and the leverage of the second set about the gun arm pivot are so arranged that the gunner's weight just balances that of the gun arm, the seat and gun arm moving in opposite directions. Adjustments of the leverage of the rams coupled to the gun arm permit accurate control of the degree of balance between gunner and gun, to cover variations in gunners' weights.

A reversible pneumatic motor, geared to the turret, provides power to rotate the turret bodily on its bearings, thereby training the gun in response to pressure exerted on the handle by the gunner as he follows his target through the gun-sights. In this way rapid movement of the gun vertically and horizontally follows upon exertion by the gunner of the small muscular efforts applied in the normal processes of training his weapon on the target.

Existence of an open gun slot some three or four inches wide extending from top to bottom of the turret has been found to produce astonishingly little draught in the turret; and when the gun is not in action, what draught there is can be excluded by stowing the gun at the top of the turret and closing the slot with a canvas strip held together by a lightning fastener. Further, the turret is warmed by hot air drawn from a heater muff on the engine exhaust pipes and remains comfortable in the most severe weather. Access to the turret is gained through a doorway into the front of the fuselage. An emergency exit, for use either for a parachute departure or in the event of a

MODERN AIRCRAFT ARMAMENT EQUIPMENT



LEWIS GUNNER

DOMED TOP -
DETACHABLE FOR
EMERGENCY EXIT

LEWIS GUN -
MOVABLE FROM
VERTICALLY UP
TO
VERTICALLY DOWN

GUNNER SEATED
ON HYDRAULIC RAM
THAT BALANCES
GUN - AS GUN
GOES UP SEAT
GOES DOWN

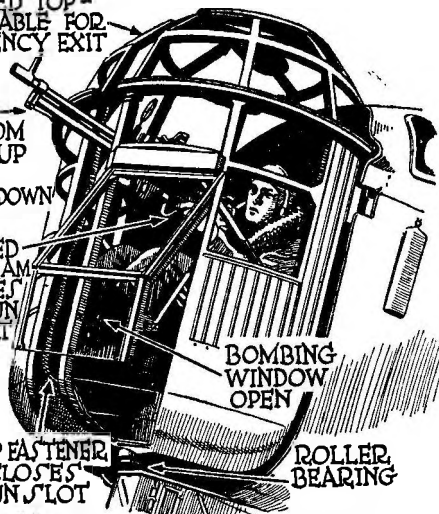

**BOULTON-PAUL
GUN TURRET**



**VICKERS
ARMSTRONG
37-mm. GUN**

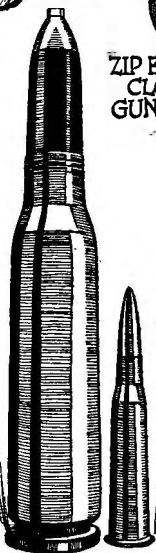

**COMPARATIVE SIZE
OF 37-mm. SHELL
AND .303 BULLET**

AIR COMPRESSOR
FOR LOADING CANNON,
STARTING ENGINE &
OPERATING WHEEL BRAKES

60-ROUND
MAGAZINE
ATTACHED
HERE

REAR
BUFFER

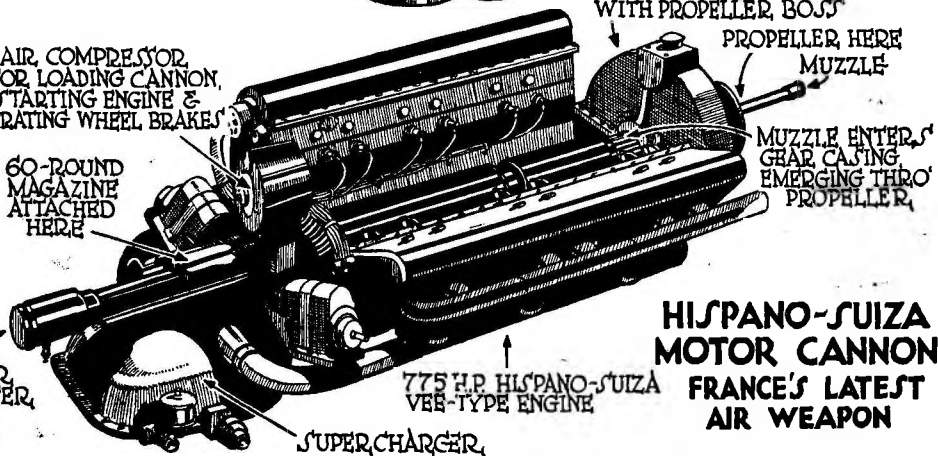

**HISPANO-SUIZA
MOTOR CANNON
FRANCE'S LATEST
AIR WEAPON**

AIR STORIES

crash, is provided by making the upper part of the top turret dome detachable.

Power to operate the turret is obtained from an engine-driven six-cylinder air compressor, which keeps a set of compressed air bottles charged to a pressure of 200 lb. to the square inch. In the event of failure of the engine to which the system is linked, the bottle capacity is sufficient to work the turret for fifteen to twenty complete revolutions. The rate of rotation normally possible is about 12 revolutions a minute.

British technicians are actively engaged in the further development of power-driven gun-mountings of various kinds, but details of their more recent achievements may not yet be divulged. Meanwhile, however, enough experience has been gained in the use of gun turrets in the R.A.F. to show that the device has wrought a great change in air fighting tactics. It has enhanced the fighting power of the multi-seat aeroplane, and has made attack by single-seaters far more difficult. To-day the manually-operated gun-mounting with its extravagant demands on the physique and endurance of the gunner is obsolete, and all the new multi-seat warplanes now in production for the expanded Royal Air Force are fitted with some kind of power-driven turret.

It may also be claimed without fear of dispute that in the design of aerial gun-mountings Great Britain is now well in advance of the rest of the world. And that we intend to retain our lead is perhaps evidenced by the fact that whenever our latest types of multi-engined aircraft are seen in public their gun positions are invariably either screened with fabric or are obvious dummies.

Fewer "Blind Spots" on Bombers

NEXT in importance to the efficiency of the guns themselves is their position on the aircraft. No designer has yet, we believe, succeeded in producing a machine entirely free from "blind spots," though some of our latest type multi-seaters must closely approach this ideal and can be attacked

with impunity from very few and limited angles. A good example of efficient armament distribution is provided by the Mark 2 Handley Page Heyford heavy-bomber with its three "free" gun positions. One of these is in the nose, another is mid-way along the top of the fuselage, while the third is in a retractable and rotatable turret known as the "dustbin," which can be lowered so that it projects beneath the fuselage and enables the gunner to repel attacks from the normal bomber's "blind spot" below and behind the tail.

In the Boulton Paul Overstrand, which is similarly armed, attack from this direction is guarded against by a tunnel in the floor of the fuselage in which the gunner lies flat on his stomach to operate the guns. Yet another effective method of combating attack from the rear is by a turret in the extreme stern of the aircraft, a practice that is being widely followed in the R.A.F.'s latest types of heavy bombers.

The result of this concentration of machine-guns on multi-seat aircraft is to make such machines exceedingly formidable objects for attack by fighters, and herein lies the chief reason for the growing popularity of the aerial cannon or shell-firing gun for single-seater fighters. The average machine-gun with which most bombers are now equipped has a maximum effective range of not more than about 200 yards, whereas cannons are effective from ranges from 500 yards to over 1,000 yards and enable a fighter so equipped to remain well out of the bombers' range while delivering its attack.

As has already been mentioned, the R.A.F. do not appear to be greatly impressed by the cannon's advantages, though it is certain that their technicians are keeping well abreast of its development and, later, may possibly be converted to its superiority. Meanwhile, however, R.A.F. adoption of the weapon has been confined to the equipment some time ago of a squadron of Blackburn Perth flying-boats with 37-mm. Vickers-Armstrong quick-firers firing a 1½-lb. shell. Abroad, adoption has

SKY GUNS OF TO-DAY

been on a very much more extensive scale, and France, Poland, Belgium and Turkey are but some of the nations which have already adopted the small-bore cannon as standard equipment for their air services.

The weapon has undergone vast improvement since Guynemer first had one fitted into the casing of his Spad's Hispano-Suiza engine in mid-1917. Guynemer's cannon was of 37-mm. calibre (1.45 inch) and the recoil from its one-pounder shell was so fierce and unbalancing to his machine that he soon abandoned its use, leaving it to René Fonck to adopt and successfully develop at a later date.

To-day, even when two cannons are in simultaneous use, their recoil force, totalling perhaps 460 lb., is scarcely felt, though on their ceasing to fire the pilot may experience a slight forward acceleration of the machine. Modern cannons vary in calibre from 20-mm. to 37-mm. and may be carried as "out-board" guns mounted in the wing-roots or undercarriage "trousers," or incorporated in the engine, in which case they are known as *moteur canons*.

The most successful *moteur canons* yet built, and the only ones so far to go into quantity production, are the two models built by the French Hispano-Suiza company to whose constant faith in and persistent development of this type of weapon the present cult of the cannon is largely due. The two types now being built are the 690 h.p. and the 860 h.p. Hispano-Suiza. Both are twelve-cylinder, "vee"-shaped water-cooled engines, and carry a 20-mm. quick-firer lying on the top half of the crankcase between the two banks of cylinders and firing through the hub of the airscrew shaft (*see illustration on p. 323*). The actual gun weighs about 100 lb., to which may be added another 60 lb., representing the weight of the 60-round magazine. The rate of fire is about 400 rounds a minute, and though the effective range is not divulged, the projectiles are said to have a muzzle velocity of some 2,890 feet/sec. and may be of the explosive, tracer, incendiary or armour-piercing type.

Multi-Cannon Installations

AT present only one gun can be incorporated in a *moteur canon* and the engine used must be of the "vee" type. If, therefore, more than one gun is required, or the aircraft is fitted with a radial engine, the cannons are carried outboard, as in the Polish P.Z.L. P.24, or the latest French low- and high-wing Loiré *pluri-canon* fighters. Such guns are usually mounted on a framework inside the wing between the spars, in cavities in the undercarriage fairing or even in the undersides of the fuselage on twin-engined machines. The cylindrical magazine is inserted into the gun before flight through a removable panel or door and, in the air, the gun is loaded by means of a lever in the pilot's cockpit which inserts the first round into the breech. The ordinary types of gun-sights already described are used and firing is controlled by a press-button or trigger on the control column. A second trigger operates safety-catches on the guns which must be released before the gun can be used.

There are several types of highly-efficient cannons now in production, of which the Madsen and the Oerlikon are among the most widely used. The Oerlikon is of 20-mm. calibre and, when fitted with a full magazine holding sixty shells, weighs 160 lb. The muzzle velocity of its projectile is 2,700 feet/sec. or slightly less than that of the Hispano *moteur canon*.

The Madsen gun is of 23-mm. calibre, and though weighing much the same as the Oerlikon, claims to be capable of firing shells of double the explosive power. Two of these guns, in addition to three machine-guns, are fitted to the latest type of Fokker fighter, the twin-engined two-tailed Fokker G.I, which created so great a sensation at last year's Aero Show in Paris. Like several of the latest types of French twin-engined fighters, the Fokker G.I has its batteries of cannons and machine-guns mounted actually in the fuselage, but whereas the French craft have their cannons projecting below the fuselage, in the Fokker they bristle from the nose of

AIR STORIES

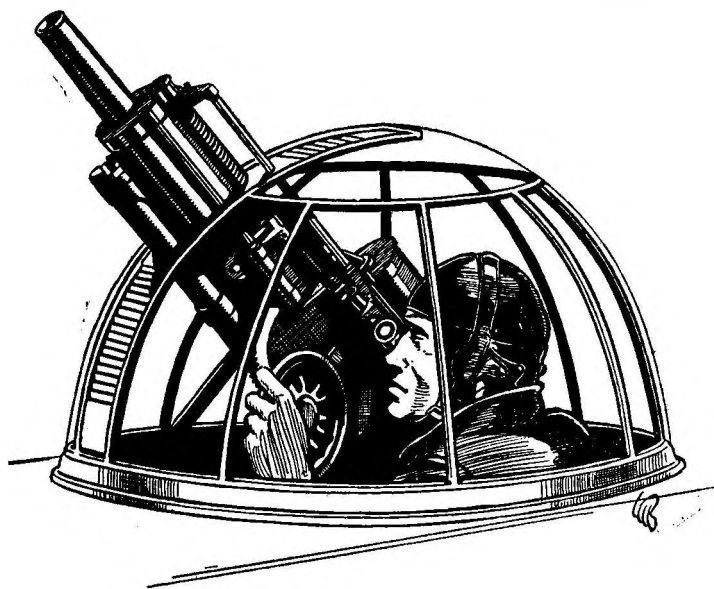

The American Armament Corporation's 37 mm. cannon as it would appear installed in a rotatable turret

weighing just under $1\frac{1}{2}$ lb., this cannon takes a clip of five rounds of ammunition, and its maximum rate of fire is 100 rounds a minute. The total weight of the gun and its mounting completely installed is 235 lb., and it has a maximum recoil force of 1,000 lb. which, it is claimed, can very easily be withstood on any modern two-seater aircraft. The large size of the projectile permits of the use of a sufficient quantity of explosive to ensure the destruction of an enemy aeroplane with a single shot, and also allows of making it impossible for the shell to be accidentally exploded

the pilot's nacelle. The four guns may be used singly or in various combinations and are loaded and fired by a combined pneumatic and hydraulic system. Two of the 7.9-mm. machine-guns are mounted well forward in the nose, the Madsen cannons being slightly further aft so that their breeches are easily accessible to the pilot's cockpit. Instead of the usual 60-round magazine, the shells for the Madsen guns are carried in belts which give each gun a reservoir of 100 rounds. The Madsen's rate of fire is about 400 rounds a minute, and each shell is so fused as to cause it to explode ten seconds after discharge should it miss its target, a precaution to prevent the projectile from dropping to the ground and causing damage in friendly territory.

A Revolutionary Air Weapon

IT is to America, however, that one must turn for what is undoubtedly the most highly-advanced form of shell-firing gun yet developed. This is the 37-mm. cannon of the American Armament Corporation which may be used either as a fixed gun mounted in the nose of an aeroplane or as a free gun in a rotatable gun turret. Firing a shell

in the bore of the gun, a precaution impossible in shells of smaller calibre.

The most remarkable and significant feature of this new cannon, however, is its claim to an effective range of nearly 1,000 yards—nearly five times that of a machine-gun and approximately twice that of a 20-mm. aircraft cannon. Thus a bomber armed with a 37-mm. cannon could easily outrange any attacking fighters equipped with machine-guns or small calibre cannons.

This formidable new cannon may, therefore, mark the beginning of a new chapter in air fighting history for, starting as a fighter's weapon, the aircraft cannon now seems likely to turn upon that type of aircraft and to bestow upon the bomber an almost impregnable defence against any attack that can be made against it in the air. Certainly it is a new weapon that must inevitably have a marked effect upon the future trend of aircraft armament, and the time may yet come when the Royal Air Force, converted at last to the cult of the cannon, will have reason to be thankful for the foresight of the private enterprise that recently secured the British rights of the new American cannon and arranged for its manufacture in this country.

The Ace who Hated Two-Seaters

High on the List of British Aces, Captain G. E. H. McElroy of the famous "Forty" Squadron, Scored 46 Victories of which more than Half were Dangerous Two-Seaters

By

A. H. PRITCHARD

THIS month's biography is of a brilliantly - successful yet little - known British air fighter, Captain George Edward Henry McElroy, M.C., D.F.C., a pilot whose forty-six victories over enemy aircraft place him tenth on the list of British "Aces."

As is so often the case with our fighter pilots, little information is available regarding his early life, and there is even some controversy as to whether he was born in Ireland or Canada. The most reliable sources of information state that he was the son of an Irish schoolmaster, and was born at Donnybrook, Dublin. Canadian records, however, claim that he hailed from Windsor, Ontario, and the author has never been able to sort out the tangle. The most likely solution seems to be that he was born in Ireland, went to Canada, and came to England shortly before the War.

Beyond dispute is the fact that he enlisted on August 18th, 1914, and served for many months as a despatch rider between London and Woolwich Arsenal



Captain G. E. H. McElroy, M.C., D.F.C.

before being granted a commission in the Royal Garrison Artillery. Firing chunks of cold steel at an unknown and unseen enemy held no appeal for a man of McElroy's aggressive spirit, and late in 1915 he applied for a transfer to the Royal Flying Corps, an application that was officially accepted on February 9th, 1916.

Posted to 40 Squadron

AT the start McElroy showed little promise as a pilot, and a long series of crashes while training kept him in England, even during the trying period of "Bloody April," 1917, when every pilot, no matter how mediocre, was needed at the Front. Eventually, however, he managed to put in a few anti-Zeppelin patrols, and, having survived a reasonable period of flying without a crash, he was packed off to France. He arrived at Bruay Aerodrome on August 23rd, 1917, to fly a Nieuport Scout for No. 40 Squadron.

Within a week of his arrival at the

AIR STORIES

Front McElroy came within a hair of being returned to Home Establishment by completely wrecking a Nieuport through a faulty landing and giving a repeat performance only four hours later. How he managed to persuade his C.O. to keep him on is a mystery in itself, for "40" was then the crack squadron of the R.F.C. and had no time for a pilot who was not perfect. He could not even record a combat for eight weeks, and it was not until the squadron received S.E.5's in October that he began to prove his worth.

Then, on December 28th, he destroyed an L.V.G. two-seater, and this first success acted like a charm, for he secured a double victory on the last day of 1917. Becoming separated from his patrol, he came upon a flight of seven enemy scouts, busily shooting the wings of a lone Camel, near Lens, and at once went down on the enemy formation. Intent on the Camel's death dive, the German pilots failed to notice this new menace, and two yellow and grey Albatroses went down in flames before a single fifty-round burst from McElroy's gun. The S.E.5 was well on the way home before the five survivors realised that the Hammer of Thor had swept two of their comrades across the River Styx without their having fired a shot in return.

The New Year found McElroy in his element, and his pet aversion seems to have been photographic or infantry "strafing" machines, his victory list showing no less than twenty-five two-seaters. And to those who may be thinking that McElroy was merely a "cold-meat expert," the following facts may be enlightening. The German two-seaters of 1918 were far from being "cold meat," and many a famous "ace" thought twice before attacking the armoured L.V.G.'s, Rumplers, Halberstadts, and, most formidable of all, the Hannoveraner. The famous "Jimmy" McCudden was shot down out of control on January 3rd by the gunner of a "Hanna," and he wrote :

"This new Hun is deceptive and I am betting it is armour-plated. It is going to cause us some trouble."

Nevertheless, McElroy soon proved that the "Flying Whale" held no terrors for him, and his victory log shows twelve of the biplane-tailed two-seaters. McElroy, therefore, was very far from being a cold-meat and lame-duck hunter.

McElroy's Fine Marksmanship

ON January 16th he destroyed two O.D.F.W.'s and sent one of the six protecting Pfalz Scouts down "out of control." The first two-seater fell in flames, the second plunged earthwards with a living observer vainly trying to pull his dead pilot off the controls, and the scout dived into the clouds with its engine coughing fitfully. Two days later McElroy caught a Hannoveraner over the lines, and a well-placed burst from his wing Lewis made the machine jump spasmodically, as though the pilot had been mortally wounded and was trying to keep his hold on the stick. The violence of its manœuvres caused the wings to give way, the whole machine then disintegrating in mid-air.

Like all great air fighters, McElroy was a dead shot and trusted his guns to one man—himself ! He picked his own ammunition, sighted his own guns, and supervised the conditioning of his machine. Just how well this meticulous care was to stand him in good stead may be gathered from the fact that, at this time, the S.E.5's were having so much engine trouble that pilots were forbidden to cross the lines unless at a height sufficient to enable them to glide home. Yet McElroy daily flew miles into German territory and only had engine trouble once—when flying a borrowed machine.

February was an eventful month for McElroy for, in addition to seven victories in a fortnight, it brought well-deserved reward in the shape of the Military Cross and promotion to captain, and a transfer to another squadron.

He opened his scoring on the 3rd and destroyed a Pfalz D.3, following up with two L.V.G.'s on the 5th, an Albatros Scout and a Hannoveraner on the 11th, and two more photography machines on the 18th. Then came the promotion and

THE ACE WHO HATED TWO-SEATERS

the transfer to No. 24 Squadron, a move which brought about a change in his fighting tactics. As a Flight-Commander he could no longer sally forth after high-flying two-seaters, for he now had to lead offensive patrols, and that meant dog-fights with enemy scouts. How did he succeed against the single-seater? Well, in five weeks he destroyed thirteen scouts and one Rumpler and used his spare time in ground-strafting expeditions. His energy was untiring during the great March retreat, and five patrols a day became almost a habit with him.

On March 8th McElroy led his patrol against a mixed formation of Fokker triplanes, Pfalz D.3's and Albatros D.5's, and at the end of the fight his score had risen to seventeen. At the very opening of the engagement a green Pfalz half-rolled across his sights and a quick burst sent the E.A. tumbling earthwards with a long pennant of black smoke to mark its passage. Narrowly escaping collision with a blazing Pfalz downed by another member of his flight, McElroy turned on a black-and-white striped triplane, sent a fifty-round burst through the main wing bracing, and with one plane folded backwards, the triplane went down in a crazy spin. Next day he attacked nine triplanes over Bohain, shot one down and chased the others back to their aerodrome. That same afternoon he met a Halberstadt "strafting" a British advance post and within a few seconds had riddled pilot and observer.

A Man Inspired

CONTINUAL fighting had brought his score to twenty-eight by the time the Germans began their great push of March 21st, and on the first day of the attack he reported no less than eight combats. While harrying the advancing enemy infantry with machine-gun fire and 20-lb. Coopers bombs, trouble appeared in the shape of three Albatros Scouts. In less than five minutes two had gone down completely out of control and the other had tumbled earthwards with a dead pilot in its cockpit. As luck would have it, our own infantry were retreating too fast to notice the fight and

McElroy received credit for only one. Returning homewards to refuel and take in more bombs, he had four "no result" fights and had to break off a fifth when he ran out of ammunition. Later in the day he downed an armoured L.V.G., and followed this up with an attack on an enemy machine-gun nest.

For the next three weeks McElroy was in the air for almost every moment of daylight, and, fighting like a man inspired, he registered thirty-four victories before, early in April, the inevitable happened and he wore himself out. Much against his will, he was ordered home for a complete rest, and in his absence Germany almost regained control of the air when her pilots received the Fokker D.7.

Back in England, McElroy heard the stories of the new German effort, but, despite his pleas, eleven weeks slipped past before he again saw France, and it was not until late in June that he was posted back to his first love, No. 40 Squadron. This, the scene of his early triumphs, was fated to see the close of his eventful career, for within six weeks he had scored twelve more victories and lost the final round with Old Man Death.

On Fire in the Air

ONCE back in action, McElroy lost no time in increasing his score, and a week after his return to the Front he attacked the German balloon line at Annay, sent one "sausage" down in flames, and so badly damaged two more that they were unfit for further service. Considering that an observation balloon cost about £800, it was quite an expensive morning for the German Balloon Service!

On July 1st he led two S.E.5's against four Fokker D.7's and sent one down to crash in Lens, while his two companions accounted for one in flames, and the remaining two "out of control." Next morning he caught an Albatros D.5 over Estaires, and that, too, went down—a flamer. For a week enemy aircraft seemed to avoid him, but on the 10th he started a remarkable run of victories and downed seven Hannoveraners in twelve days. Short of metal, the German designers were turning out the new

AIR STORIES

"Hannas" with no protective armouring round the cockpits, and McElroy was not long in discovering this lapse.

It was while attacking a "Hanna" near La Bassée on July 20th that death first reached out for him. A loose connecting rod in the engine of his borrowed machine gave way and fire quickly enveloped the machine. With angry flames leaping ever nearer to his cockpit, McElroy did the only thing possible—side-slipped the machine to the ground and threw himself out of the cockpit. His luck held good and he emerged from the flames with nothing worse than scorched clothes and a bruised knee.

Five days later he was returning from an attack on a munition convoy when he encountered two more of his old friends, and this—his last fight—was one of the fastest in his career. His opening burst was fired from an abnormally long range,

but it did the trick, and the German pilot collapsed, shot through the head. The observer of the other Hannoveraner had just time for one burst at the elusive Britisher before steel death beat a tattoo along his fuselage, snuffing out his life and marching on through the front cockpit.

Captain G. E. H. McElroy took-off in the early morning mists of July 31st and never returned. Just what happened to him remains a mystery to this day, for the only news that reached his squadron was that he fell near Laventie. Did enemy ground fire claim him, as it claimed many another air fighter, or did he finally fall a victim to some gunner of the old Hannoveraner? These are questions that may never be answered on this side of the "Great Divide," but certain it is that he died as he had lived—a courageous fighter and a very gallant gentleman.

IN NEXT MONTH'S ISSUE

"ORDER OF THE BATH"

A Long Complete Story of the Strange Adventure that befell an R.F.C. Camel Squadron on the Western Front

By **G. M. BOWMAN**

Popular Author of "Death of a Hero", and "For Services Rendered"

And Two Great Modern Air Stories of the R.A.F. in Action

ARABIAN FLIGHT

By

A. J. PELHAM-GROOM

HIMALAYAN HELL

By

J. H. STAFFORD

These, and many other Thrilling Stories of Air Adventure, in Fact and Fiction, appear in the May Number of

AIR STORIES

On Sale, April 10th.

Price Sevenpence

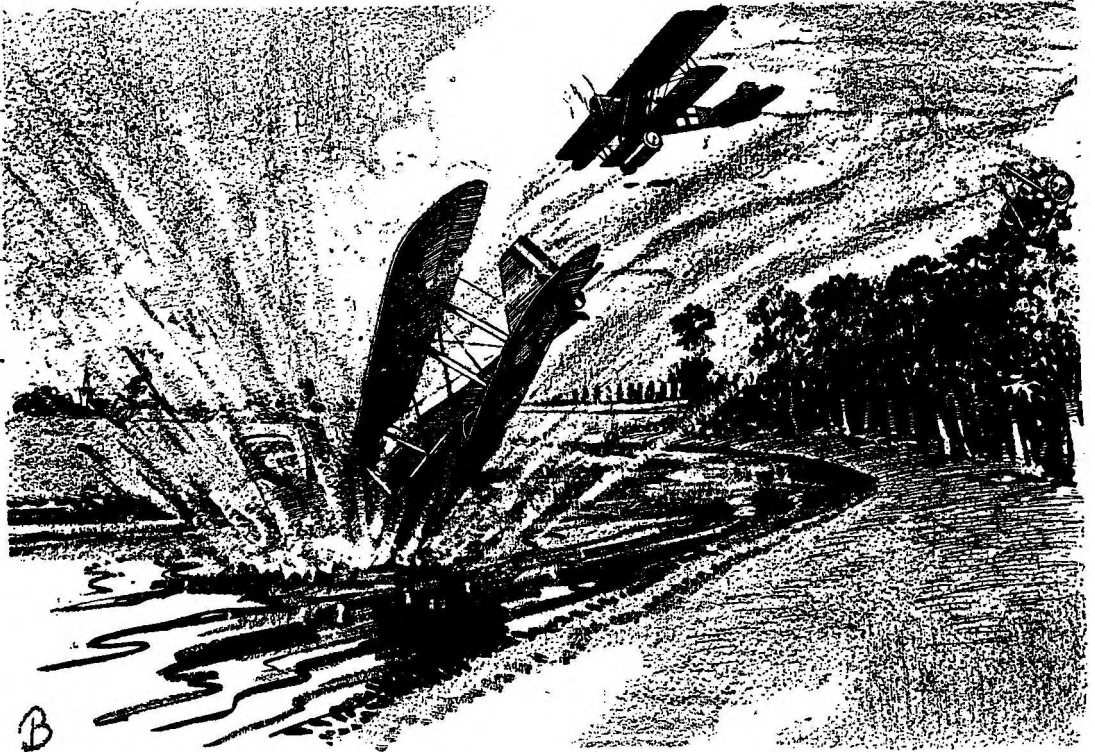

Leaving its undercarriage on the tree tops, the 'plane hurtled on to plunge into the river

ESCAPE

An Unusual Story of a Prisoner-of-War to Whom No Price was Too Great to Pay for the Chance of Escape

By F. I. HURLEY

TOM DAVIES hated war. He maintained that if there had to be war, then some of its ancient chivalry should be preserved. He detested its wholesale slaughter—gunners firing shells that killed people they did not see and probably never had seen before. Young men and boys going out to France, full of enthusiasm and loyalty to their country, only to be wiped out by a shell to lie forgotten in the mud of the battlefields.

It was Tom's ideas about war that led him to join the R.F.C. Not through any fear of being killed, but because he preferred the thought of private duels with the enemy in the manner of the knights of old. But, even in the R.F.C., the duel was beginning to die out. Formation flying was being developed, and it was a

case of squadron against squadron, not man against man.

Tom Davies had been posted to No. 125 Squadron, which was stationed near Bar le Duc and was equipped with S.E.5's, which had just replaced its Sopwith Pups. For the last fortnight the squadron had suffered heavy losses. Tom had hoped that the S.E.'s would put an end to that, but only this morning they had come off second best in a scrap with a German squadron.

As he sat in the mess drinking his coffee Tom went over the events of the morning. "C" flight had taken-off for the dawn patrol. Over the lines they had met a flight of Albatros and, during the ensuing dog-fight, two "C" flight machines had been shot down and only one German. Then Barclay had given the order to re-form the flight and they

AIR STORIES

high-tailed it for home. On the way back, Tom had noticed that Barclay was flying crookedly and jerkily. Over the aerodrome they broke formation and landed one by one. Barclay was the last to land. He came in very sloppily, stalled just off the ground and buried the machine's nose in the middle of the field.

Tom had been one of the first to reach the wreckage. Fighting his way through the mass of broken struts and wires, he had reached the cockpit, undone the safety strap and dragged Barclay's limp body out. The flight leader was dead. He had stopped four bullets and, according to the doctor who examined him, had died before the 'plane crashed. Now the wreckage had been cleared away, the hole filled up, and there was a new grave in the little cemetery at the back of the hangars, marked with Barclay's own propeller.

Tom got some more coffee, sat back in his chair and looked round the mess. Several people were playing cards; others were writing letters. Bill Jones was thumping out a tune on the rickety old piano, and there was a group round him shouting the words:

*"As a pilot in France I flew over the lines
And there met an Albatros scout.
It seemed that he saw me, or so I presumed;
His manœuvres left small room for doubt,
For he sat on my tail . . ."*

Tom finished his coffee and went out.

He went over to his hut and sat down. Barclay was dead. It was hard to believe, yet there was his empty bed and his kit packed ready to be taken away. Barclay and he had been great friends. They had first met at a training school in England, had come out to France together, and were now practically the oldest members of the squadron. For four months they had fought and flown together. And now Barclay was dead. To-morrow, Tom would have to lead "C" flight on the dawn patrol. The mechanics had already taken Barclay's streamers off the wreck and attached them to his own S.E.

THE sky was brightening in the east with the first touches of dawn. On the field of No. 125 people were beginning

to move about. Mechanics were wheeling machines out of the hangars. One engine roared to life then spluttered into silence. Another started, coughed, but picked up again. Soon the whole field was alive. Men ran from hut to hangar, pulling on flying gear—small black figures against the morning light.

There was a knock on Tom's door. He turned over sleepily and muttered "Come in." His batman entered with a steaming cup of coffee. Shaking Tom awake, he said, "You're on dawn patrol this morning, sir."

"Oh, hell!" groaned Tom, rousing himself with an effort. "What's the weather like this morning, Briggs?"

"There's a slight west-south-west breeze, sir," replied his batman. "It's fairly clear, but a bit cool."

Tom knew that meant that it was freezing, and he cursed dawn patrols and those responsible for them.

He moved mechanically over to the other bed to drag Barclay out of it and saw that it was empty and unslept in, with Barclay's kit folded neatly at the bottom.

He stared at it in silence. Only yesterday Barclay had been planning how to celebrate his twenty-third birthday. Now he was dead and buried, and Tom would have to lead "C" flight on the dawn patrol—on every patrol until, perhaps, he too was killed.

Fifteen minutes later Tom was sitting in the cockpit of his S.E.5. He opened the throttle and watched the rev.-counter rise as the machine strained against the chocks. When he was satisfied, he slowly closed the throttle and looked round at the flight to see if they were ready. Then he gave the signal and his chocks were pulled away. Opening the throttle he taxied across the field, swung round into the wind, and took-off with the rising sun behind him.

At five thousand feet above the aerodrome he waited for the patrol to get into formation. His orders were to patrol their sector on the German side of the lines. The brass-hats seemed to want their aeroplanes shot down. They were sure to run into at least one enemy flight.

ESCAPE

Soon they were crossing the shell-torn strip of No Man's Land at fifteen thousand feet. Archie had started firing, and black blobs burst below the 'planes, growing rarer as they proceeded.

Although the morning was bright and sunny, the ground was white with frost and a chill wind blew. At fifteen thousand feet it was very cold and all the pilots of "C" flight were wishing that the dawn patrol was over. Breakfast would be ready in the mess. It would be warm there. Anything was preferable to this cheerless patrolling.

The sky was clear except for a cloudbank in the west, which was being blown in their direction. Woods looked across at Campbell. Campbell put out his tongue. Woods replied by thumbing his nose. Then Campbell held his hands over an imaginary fire and rubbed them together. Woods shivered and turned away.

Tom, in his position as leader, felt strangely lonely. Before there had always been someone in front of him and beside him. Now he had to look behind him to see the members of his flight. He looked around him for enemy aeroplanes. The cloudbank had come up very rapidly and now almost covered the sky. There was ample cover for a hundred E.A., let alone one flight. He glanced at the ground below and then at the watch on his dashboard. Time they were turning back. Thank goodness the patrol would soon be over. He started the wide banked turn that would take his flight farther into German territory.

Tom looked at his wings and his two streamers caught his eye. Flapping and cracking in the air, they made him realise the responsibility that was on his shoulders. Not only was he responsible for his own life, but also for those of the four other members of his flight. And the safety of their machines as well. . .

THE Germans were upon them before they knew it. There were five of them—the odds were equal. But the enemy had the advantages of height and a surprise attack. They had come out of the clouds above and behind the S.E.'s.

Tom went into a quick climbing turn, rapidly surveyed the fight, and singled out a Fokker that was attacking Woods from above while another sat on his tail. Tom fired a burst from the Vickers to warm them up and came down behind the Fokker. At his first burst the Fokker sheered away from Woods and went into a climb.

Then the circling began. The Fokker was painted a bright blue with a white "4" on its fuselage. The pilot's scarf trailed stiffly behind him in the slipstream. Tom could not see his face.

The S.E. began to gain. Little by little he crept towards the tail of the Fokker. A little more and his sights would be on the cockpit. The German turned round. It seemed to Tom that his face was white with the fear of death, but it may only have been his imagination. He pressed the trigger buttons, the grey tracer bullets flew towards the Fokker and a row of black dots appeared in his tail-plane. Tom moved the stick slightly and his next burst went nearer the cockpit.

The Fokker zoomed. Tom followed, and as he did so he saw a thin line of black smoke in the sky to his left. Someone was down, but whether British or German he could not tell. He went after the Fokker again. He fixed his sights on the fuselage and pressed the triggers, and this time his bullets bit just behind the pilot. He moved the stick slightly and once more pressed his trigger. The Fokker zoomed again, but this time it fell to one side and went down in a fast right-hand spin, the dead pilot's arm hanging over the side of the fuselage. As Tom watched the 'plane falling, one of the wings came off, to be followed by the other. The fuselage plunged earthwards, the rest of the wreckage floating down after it.

Tom had come down quite low, watching the Fokker crash, and as he started to climb to re-assemble his flight he saw another Fokker behind him. It was too late to do anything. The German had already started firing. Black holes appeared in his wings and the torn canvas flapped back and showed the bare ribs. Tom kicked the rudder-bar madly, but

AIR STORIES

still the bullets hit his 'plane. He zoomed and swerved again. For a second the shots ceased. Then they started again. There was a sharp metallic clang as one of them struck the engine. The propeller flew to pieces in front of him, and the engine raced madly. Tom switched off and headed for his own lines. There was a very small chance that he might reach them in a glide.

He glanced at his altimeter—nine thousand feet. Not much hope, but he might do it. The German flew in front of him and pointed to the ground. Tom pressed his triggers by instinct, but the synchronised Vickers was useless now without the engine. The Lewis's drum was empty.

There was the sound of machine-guns behind him. He moved the rudder-bar over but the 'plane did not respond. He moved it farther, and still nothing happened. The rudder wires must have been shot away. He moved the stick and went into a dive. The Fokker was still behind him, and bullets spattered the tail-plane. He tried to pull the S.E. out, but the stick only came part of the way back, and suddenly something snapped and it moved loosely about in its socket. The machine was going down in a fairly steep glide, and through his wings Tom saw a silver ribbon of water winding amongst the trees and fields that gradually came closer to him. Through his centre-section he saw woods, a road, and then a village.

The trees approached with alarming rapidity until they filled the whole of his centre-section. He pulled desperately on the stick. The 'plane seemed to respond slightly and level out a bit. The undercarriage tore through the tops of the trees and wrenched itself away. The machine hurtled across a strip of grass and plunged into the river, sending up a spray of water on both sides. The wings were bent back about the fuselage; a cloud of steam rose from the hot engine as it touched the water. There was a roar as the German 'plane flew overhead. Then all was quiet again. The river flowed silently by, making small eddies around the stricken 'plane. In the trees the birds sang. The rumbling of guns

could be heard in the distance. A clock in the village half a mile away struck a quarter to seven.

A GROUP of German reserves were stationed near a ruined French village behind the lines. They were encamped in a field beside a road lined with poplars. On the other side of the road was a small river. The reserves had been there for two days and were waiting for orders to move up to the front. They were living in dug-outs, and spent most of their time trying to hide from the prying eyes of enemy airmen.

One April morning an officer of the reserves awoke with the sound of an aeroplane engine in his ears. The sound was not uncommon, but if it was an enemy machine there might be something to reveal the presence of the reserves; it was his duty to see that this did not happen.

When he emerged from his dug-out he found not one but ten aeroplanes in the sky. Five Allied and five German aeroplanes were engaged in a scrap. They were a good distance away, but near enough for their machine-guns to be heard.

Two 'planes began to drift over in his direction. The German was behind the British 'plane. A machine-gun rattled and the British 'plane went into a steep dive. When it got near the ground it pulled out a little. With whistling wires and a dead engine it tore through the trees, and the officer heard it splash into the river.

He called four men and they made towards the 'plane at a run. The four men waded into the river, and hacked their way through the tangle of splintered wood, torn canvas and trailing bits of wire that had once been wings, to the cockpit and its motionless occupant. They undid the safety-strap, pulled him out of the cockpit and laid him on the grass. One of the soldiers took off his helmet and undid his heavy flying coat. The officer stood a little apart, looking through the pilot's papers.

Apart from a gash on his head, which he probably received when his 'plane hit

ESCAPE

the water, the pilot was unhurt. One of the soldiers, using the pilot's helmet as a water bag, fetched some water from the river, bathed his wound and tied it up roughly with an old and rather dirty rag. Two of the men then lifted him and carried him across the road to one of the dug-outs.

By now the clouds had passed and the sun shone brightly out of a clear sky. The clock in the village struck seven.

TOM DAVIES' first feelings when he returned to consciousness were that he was on a boat in a very rough sea. He was being bounced up and down in an irregular fashion. There was a sharp pain in his head. He put up his hand to feel it and it came away sticky. He opened his eyes and saw the back of a man, and found he was on a stretcher being carried along a dusty, poplar-lined road. At first he thought he was on the English side of the lines. Then he saw that the man in front of him was in German uniform. He was a prisoner.

He closed his eyes and tried to think. There had been a fight, he remembered, a Fokker had sat on his tail and he had crashed, out of control, into the river. Now he was a prisoner in the enemy's hands. He would probably be interrogated and sent to a German prison camp.

A shadow fell across his face. He opened his eyes and saw that they were entering a village. Piles of ruined masonry lay across the street. The houses all seemed empty. Ahead of him was what appeared to have been the town hall. In the tower above it there was a clock which said 7.25. Whether it was going or not Tom could not tell. At the foot of the town hall steps the stretcher-bearers stopped. At the command of an officer, whom Tom could not see, they went up the steps and through the door on each side of which was a sheet bearing a red cross.

Tom's wound was quickly dressed and the doctor, a stout, fussy little man, dismissed him as perfectly fit.

Outside, the officer was waiting. He addressed Tom in German. Tom looked at him blankly; he knew nothing of the

language, and said "I don't understand you. Do you speak English?"

"A little," the officer replied, "but not . . ." He trailed off helplessly, unable to express himself. He walked beside Tom and the two guards fell in behind.

They marched down the village street, which had suffered severely from the shelling. Most of the houses were in ruins, and piles of bricks and masonry littered the roadway. The inhabitants had left when the Germans first occupied that part of France.

The small party stopped before the inn, or rather what had been the inn before the landlord left and a shell landed in front of it. The officer went inside and Tom remained in the street with the two soldiers.

A few minutes later, the officer reappeared, issued an order to the two soldiers, and beckoned Tom to follow him. At the top of a rickety flight of stairs, the officer knocked at a door and went inside. A few seconds later he signed to Tom to come in. One of the soldiers accompanied Tom, stood stiffly to attention and saluted. The other remained on guard outside.

Tom found himself standing in a small room with a bare wooden floor. A large-scale map of France, hanging on the wall opposite him, supplied all the decoration there was. Both windows were broken and there was no furniture in the room except a desk piled high with papers, at which sat a young German officer, evidently of high rank. When Tom entered his head was bent over some papers, and all Tom could see of him was his fair, cropped hair. When he looked up Tom saw that he was youngish and clean-shaven. The star of the *Pour le Merite* hung from a ribbon on his stiff-necked military tunic.

"You are Lieutenant Thomas Davies, of 125 Squadron, Royal Flying Corps?" he asked. His English was good, with barely a trace of accent.

"Yes."

"You are stationed at Bar le Duc?"

Again Tom replied in the affirmative.

AIR STORIES

"You are at present flying the new S.E.5's?"

"Yes."

"They are capable of about one hundred miles an hour, so our Intelligence officers tell us?"

Tom was just about to correct him when he saw the trap that had been laid for him.

"That is quite correct," he replied. "I must compliment your spies on their quick work."

The questioning went on for the best part of an hour. Among other things Tom was asked the position of batteries and anti-aircraft guns. In the end he was told that he could go, with the knowledge that the next day he would be sent to a prison camp in the south of Germany.

He was locked in a room at the end of a passage which contained a stretcher bed with some dirty blankets on it. The window was small, but all the panes of glass were intact.

Tom lay down on the bed. Now that he was alone he had time to think. His head was throbbing painfully and all his limbs were aching. He suddenly felt very tired. Days of long fighting and little rest had not failed to leave their mark on his nerves.

He yawned. He was a prisoner now and the war was over so far as he was concerned. He yawned again. The war couldn't last very long now—two months at the most.

Outside the guard leaned against the door. He could hear the prisoner's regular breathing as he slept. He, too, yawned and cursed his luck at having to stand guard. He looked at his watch. In another hour he would be relieved.

WHEN Tom woke up it was late afternoon. One of the soldiers was shaking him by the shoulder. He sat up and the soldier pointed to a tray of food on the rickety chair beside the bed. Tom ate the food eagerly; he was too hungry to notice its poor quality. When he had finished he felt much better; his head had almost stopped throbbing, and he no longer felt tired.

His mind had cleared too, and he could now look at his position from the other point of view. It was true that he was a prisoner and that the war was over so far as he was concerned, but he had heard stories about the cruelty and hardships that men suffered in German prison camps. Stories, yes, and they were probably nothing more than stories. And yet . . .

He remembered Dick Harris, whom he had met in London in 1915. Harris had gone out in 1914 with the B.E.F. He had been taken prisoner in November, and had been in German prison camps until September, 1915, when there had been an exchange of prisoners. Harris was one of the lucky ones. He had been wounded and his left eye had gone. As a result he was not accepted for active service again. He had told Tom that he preferred fighting in the trenches any day to being in a prison camp. Once inside the camp there was no escape. And the war might not be over in a few months. It had been going on for three years, and it might well go on for another three.

A few hours ago Tom had thought that anything was better than war and flying, but now he began to reason differently. On the flying field he was several miles behind the front. Unlike the men in the muddy, louse-infested trenches, they could eat their meals in comfort and get a wash when they wanted it. And their dead were buried decently, not left lying in shell-holes at the mercy of the rats.

Yet, bad though the trenches were, Harris had preferred them to a prison camp.

Tom got up and walked over to the window. The sun was setting over the roofs of the village, which were silhouetted against the crimson sky. Beyond the houses on the left was a row of poplars. If only he could escape and be free. To fly again and feel the cool air whipping past his face, hear the sharp crackle of machine-guns. Anything was better than imprisonment. If only he could . . .

His thoughts were interrupted by the drone of an aeroplane. He shaded his

ESCAPE

eyes and gazed into the sky above the setting sun from where the sound came. He saw a black dot and then two more. Three 'planes flying in formation. When they came closer he saw that they were German two-seaters. They swooped low over the inn, the sun bathing the undersides of their wings in a fiery glow, accentuating the black crosses. They turned in a sweeping bank, cut their engines and glided down to land behind the poplars.

Tom drew in his breath sharply. Here was a chance of escape. There was an aerodrome only a few hundred yards away. If once he could get to an aeroplane . . . But it would be madness to attempt it. Yet there might be just the slenderest chance. Tom's saner mind knew it would be madness to try, but the desire to escape was too strong for caution.

He was still thinking of the possibilities of his mad scheme when the soldier brought him his evening meal. He ate it slowly, thinking and planning. When he had finished he got up and went to the window. He was on the first floor. There was a small yard below, and a door leading into a dark side road. The town hall clock struck seven.

He decided to make his escape at midnight. He tried the latch of the window and it lifted. He gave the window a gentle push, but it did not open. He gave it another, and found that it was stuck at the bottom. He pushed harder and at last it swung on its hinges, squeaking and groaning. It seemed to Tom that the guard must have heard it. He held his breath and listened, but there was no sound. He opened the window to its widest extent and peered down. Below him he could see the roof of an outhouse. If he could reach that it would be easy to drop to the ground and get out into the street, provided the yard door was open. In the streets he would probably pass unnoticed; his heavy flying coat would hide his uniform.

He could reach the roof if he had a rope. He could tie the blankets together. He looked round to see if there was anything to fasten a rope to. There was nothing except the bed and he would have

to pull that over to the window. He dared not do that as the guard outside would surely hear it. He looked out of the window again to see if there were any other means of escape, and caught sight of a drainpipe about three feet to the left of the window. It went down to the roof below him.

Tom went back and lay on his bed. The minutes seemed like hours. He could hear the village clock slowly striking the quarters. He dared not sleep in case he should miss his chance of escape. The guards changed every two hours and each time held a short conversation. They were due to change again at twelve o'clock, and while they were talking Tom would act.

AT last the hour of midnight boomed out. Tom lay quiet, waiting, but he could hear nothing. He was just giving up hope when he heard voices outside his door, followed by a short laugh.

Now was his chance. He pulled on his flying coat and crept silently to the window. He climbed out and, with both feet on the sill, grasped the frame with his left hand. Pressing himself against the wall, he felt with his right hand for the drainpipe. He could just reach it. He shook it and it seemed firm. He felt around with his right foot and found a chink in the bricks. Then he brought his left foot up to it, let go his hold on the window-frame, and clasped the pipe with both hands. Slowly he half slid, half climbed, down to the roof, and jumped to the ground.

He looked about him. The yard was cobbled and lit by a full moon. There were no lights in the streets. There was a strong breeze blowing, and occasionally the moon was obscured by clouds.

Tom walked over to the door, keeping cautiously in the shadows. He turned the handle and shoved, gently at first and then with all his strength, but the door did not move. He couldn't stay there all night shoving at the door handle. One more attempt and he would have to climb the wall. He turned the handle and heaved with all his strength. The door did not move. He was just looking for a

AIR STORIES

place to climb the wall when it occurred to him that the door might open inwards. He turned the handle and pulled gently ; the door opened noiselessly and he walked out into the street, closing the door behind him.

There were no people about as he hurried along the street in the direction of the aerodrome. Soon he found himself following a poplar-lined road beyond the village. He had not gone far before he saw a huge black shape looming up ahead of him. It was a hangar.

He struck off from the road into a field and wormed his way through a hedge, to find himself in a deep ditch. He looked carefully over the top and saw that he was on the aerodrome, on the side opposite the hangars. He crept back and made a wide detour that brought him beside the hangars. Once more he wormed his way through the hedge.

Tom's luck was in. The squadron was a night-flying one, and the machines were being wheeled out for the night's bombing. He was about two hundred yards away from the nearest 'plane, whose engine was ticking over gently. There was no one near it, the other mechanics were busy with the rest of the machines.

A CLOUD crossed the moon as Tom climbed out of the ditch and started walking towards the 'plane. No one would recognise him in his flying coat in the dark. Yet if they did they would shoot

him. He had gone fifty yards now. Only another one hundred and fifty. Supposing the pilot of the 'plane came out and saw him getting into it ; he would be caught before he could get away. He must be half way by now. Only another hundred yards. Was that someone coming towards him ? If he came up and spoke to him . . . ! Tom's nerve broke and he started to run. The man shouted something at him. Tom ran on. Seventy-five yards more. Two shots rang out in quick succession. Tom felt something tear at his sleeve and there was a sudden searing pain in his arm. He stumbled, but recovered and ran on. The aerodrome was alive with people now. A siren shrieked. Only another fifty yards. More rifles cracked and forms ran towards him. A searchlight swept across the field and caught Tom in its glare.

From a corner of the field a machine-gun rattled. It fired one short burst. Just ten more yards. The machine-gun rattled again. Tom felt two hard knocks on his back. The 'plane loomed up close to him and he put out his hands to catch it, but it became blurred and receded from him. His clutching hands missed it and he crashed to the ground.

A crowd gathered round the body. Two men carried him into a hangar and covered him with some sacking. They buried him next day in the cemetery behind the little village church.

Tom Davies had escaped.

THE STORY BEHIND THE COVER

The Camouflaged Harrow is the Latest and Fastest Heavy Bomber to Reach the R.A.F.

WITH an exceptionally high top speed and a cruising speed considerably greater than that of any comparable big 'plane now in service with the Royal Air Force, the new Handley Page Harrow heavy bomber—subject of this month's striking cover by S. R. Drigin—represents a notable accession to Britain's striking power in the air.

First of the new type bombers, ordered in quantity under the R.A.F. expansion scheme, to reach the Service, the Harrow is already in process of delivery to R.A.F. squadrons. A high-wing monoplane fitted with two Bristol Pegasus air-cooled supercharged engines driving three-bladed controllable-pitch airscrews, it is designed to carry heavy loads over long distances and has a greater bomb capacity than that of any aeroplane previously in service with the R.A.F. It can also be quickly adapted for the transport of thirty or more

fully armed troops.

As a high-wing design makes it difficult to fit a satisfactory form of retractable undercarriage, the Harrow's undercarriage is fixed, but is so well streamlined that it gives rise to little more head resistance than a retracted undercarriage and weighs considerably less.

Of unusual interest is the camouflage colouring of the Harrow, indicative of a reversion by the R.A.F. to a practice widely adopted by both Allied and German air services during the Great War. As applied to bombers, camouflage is primarily a means of making them less conspicuous to fighter aircraft, and the Harrow's predominant colour scheme of dark green and brown is one that would obviously blend well with an average landscape and make detection of the machine from the air extremely difficult.

No. 25 Squadron R.F.C.

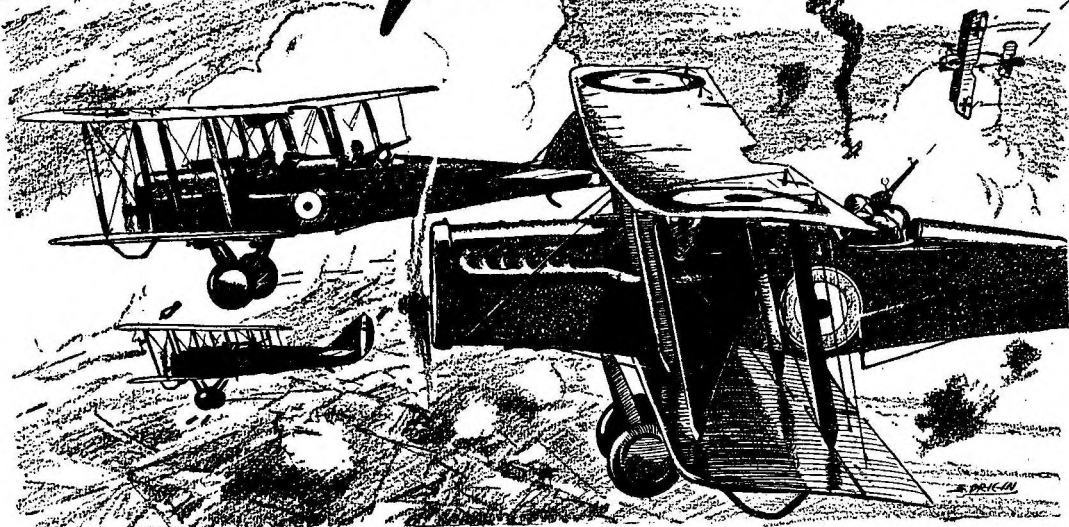

A Short History of a Famous R.F.C. Unit that began the War as a Fighter Squadron and Ended it as One of the R.A.F.'s Most Successful Day Bomber Squadrons

By W. MACLANACHAN

Late of No. 40 Squadron R.F.C.

THE formation of No. 25 Squadron was typical of the hurried development that took place in the air arm throughout the war. In the middle of 1915 aerial fighting, as such, began to take place and to combat the activities of the Fokker monoplane the R.F.C. had hurriedly to produce scout, or fighting, squadrons.

At the time No. 6 Training Squadron was stationed at Montrose, but a few strokes of the pen converted it into an advanced training and service squadron, with the new number "25." The first real indication of the purpose of this change was when four Vickers Fighters were delivered at the Squadron's new aerodrome at Thetford. These, however, were soon replaced by F.E.2b's, which were first developed as fighter machines; and in February, 1916, the Squadron was sent overseas to St. Omer with an assorted equipment of F.E.2b's, B.E.2c's and Bristol Scouts.

Their first duties were H.Q. defensive patrols by individual machines, but, in March, the general duties of reconnaissance, escorting and fighting began in earnest. For the first time tactical formations of as many as six machines were used, the reconnaissance machines being surrounded by their convoy of F.E.'s and sometimes accompanied by their Bristol Scouts. A few enemy formations were encountered, but, despite the determination of the fighters of "25" to come to grips, no decisive combats were recorded until April 27th, when three Aviatiks were driven down in a fight between four F.E.'s and six of the German two-seaters. It is worthy of record that three of the four F.E.'s in this engagement were machines presented by Zanzibar, South Australia and Montreal, and were manned respectively by Lieut. R. S. Maxwell (pilot) and Second-Lieut. S. A. Sharpe (observer), Captain Grattan Bellew, Second-Lieut. M. T. Baines and Second-

AIR STORIES

Lieut. J. S. Sharpe, and Captain W. Milne with Corporal L. Van Schaick.

From then onwards the star of "25" was in the ascendant. Their principal antagonists were the Aviatiks and Fokker monoplanes which, on account of the German "ca canny" policy, generally patrolled well inside their own lines. The F.E.'s proved themselves more than a match for the Aviatiks.

In March, Major F. V. Holt, who had commanded the original No. 6 T.S., handed over to Major T. W. C. Carthew, who was given another squadron two days later to be replaced by Major R. G. Cherry.

Fighting in Formation

THROUGHOUT April the Squadron continued its offensive patrols and escorts and it is a memorable fact that at the beginning of April, 1916, the Flights undertook what were probably the first experiments in formation flying for purely offensive patrols. They frequently set off with an assortment of F.E.'s and Bristol Scouts, and whenever they could come to grips with Aviatiks or Fokkers the pilots and observers showed their superiority over the Germans. About this time a new German fighter, the Albatros, began to appear on the front, and even against this formidable opponent the F.E.'s proved their worth valiantly. During the day, flights, then regarded as long-distance bombing raids, were carried out to Valenciennes, while the whole of the front behind the German lines was photographed.

The success of the Squadron continued but as their list of victories over German airmen grew, so did their casualties. Very frequently, the heavy F.E.'s with their 160-h.p. Beardmore engines got back to our side of the lines so badly damaged that they crashed in forced landings.

The 18th of June, a memorable date historically, was a busy one for the Squadron. Owing to low clouds, work did not begin until noon, and on the first offensive patrol no German machines were seen. Later, however, a patrol of three machines went up and only two

returned, the one piloted by Lieut. C. E. Rogers with Sergeant H. Taylor as observer being brought down on the enemy side N.E. of Arras. One Fokker was "crashed" by Second-Lieut. J. L. P. Armstrong, while Captain W. A. G. Bellew drove another down.

The next patrol had an indecisive combat with another Fokker, and just before 8 p.m. the last patrol was ordered up because of unusual activity on the part of the enemy. Just before 9 p.m. Second-Lieut. C. R. McCubbin with Corporal J. Waller as observer saw one of three Fokkers attacking the F.E. flown by Second-Lieut. J. R. B. Savage and Second A/M T. Robinson. McCubbin attacked the Fokker which dived straight into the ground to end the career of Immelman, the German ace, who had then destroyed sixteen Allied aircraft. Unfortunately, the other Fokkers took revenge, Savage being killed and Robinson taken prisoner.

Throughout June there was great activity on the Arras-La Bassée section of the front, due to the battle of the Somme being waged just to the south, and the majority of the 10th Wing patrols were O.P.'s to prevent the daring Germans wreaking havoc on our side. The tactics of the enemy seemed to vary, for on several days none of them penetrated to our side, while on others enemy patrols were repeatedly encountered.

One activity of the Squadron which had been slow in developing was that of night bombing. In March, several experimental flights had been made in a B.E.2c and each pilot had some practice in night flying and "flare landings." In May and June the practical work had been carried forward so well that at the end of June the last patrols, which were usually O.P.'s, bombed railway junctions and dumps before returning to Auchel to land in the dark.

A Courageous Engagement

AREPORT of Major R. G. Cherry, which was made at about this time, is worthy of consideration, for not only does it bear witness to the courage of 25 Squadron's fighters, but it also illustrates

NO. 25 SQUADRON R.F.C.

how difficult it was to assess the number of air victories gained by an individual. The report runs :

“ The expedition was returning from Henin Lietard (10 miles on the German side) after dropping their bombs without opposition. The rear pilots, Lieut. Riley and Second-Lieut. Sherwell, got rather behind, and, on nearing the lines, Captain Bellew, Captain Tedder and Second-Lieut. McCubbin saw Fokkers following up these last machines. Captain Tedder engaged one of these Fokkers and drove it off, but had his main tank pierced by a bullet and returned home. Second-Lieut. McCubbin engaged two Fokkers that were coming up ; his observer, Corporal Waller, shot down one of these and saw it going down out of control. Second-Lieut. McCubbin was, however, hit in the arm and had to return. He landed safely near Beuvray.

“ Captain Bellew then bore the whole brunt of the fighting. He engaged a Fokker that was following up Lieut. Sherwell's machine and drove it off. He then attacked another that was coming up, and his observer fired two drums into it at ten yards range. The Fokker heeled over and went down vertically, crashing behind the enemy's lines. Captain Bellew was then at 2,600 feet. He could see three Fokkers going E. at 1,000 feet over La Bassée. He waited about but nothing came within reach, so he came home.

“ Second-Lieut. Sherwell landed near Cambrai ; his machine was badly hit—the rudder controls were broken, most of the tail struts and booms were hit and both tanks pierced. His observer, Second A/M. Chadwick, was hit three times and died in a few minutes. Lieut. Riley landed near Mazingarbe, but his machine ran into hidden barbed-wire defences and turned over, being totally wrecked. Lieut. Riley was thrown on to his head and suffered concussion. Lieut. Bird was hit in the back, had his wrist broken and shoulder dislocated.

“ From accounts gathered by the Commanding Officer from spectators in

the Loos Salient, two Fokkers certainly crashed behind the enemy lines.”

This was the heaviest loss so far sustained by “ 25 ” but it pays a great tribute to the spirit of the Squadron. Henceforth the German activity increased and, carrying out the offensive policy of the Wing, No. 25, No. 2 on A.W.'s, and No. 16 on B.E.2c's collaborated in organised raids on strategical positions and communications, frequently escorted by the F.E.8's of 40 Squadron, also of the same Wing.

“Strafing” a Railway

A TYPICAL attack was made on September 25th. The object was to destroy traffic and dislocate communications on the long straight railway between Douai and Lille, the most important quick transport line on the northern sector of the front. As usual with 10th Wing tactics, the enemy machines had to be kept on the ground, and to effect this heavy phosphorous bombs were dropped on their aerodromes while the F.E.8's of “ 40 ” made sure that no Fokkers or Albatroses reached the bombers. A hangar was destroyed at Provin, and at Phalempin half the village was set on fire. The railway station at Libre court was heavily bombed and much rolling stock damaged, while others taking part in the raid attacked the trains working on the main line. Captain Chadwick (pilot) and Sergeant H. Brown (observer) scored six direct hits on a troop train leaving Libre court. The engine was hit and derailed, several coaches telescoped, and in the ensuing mêlée the observer fired several hundred rounds of ammunition into the German troops that alighted. Another F.E., with Second-Lieut. C. H. C. Woollen and Lieut. C. S. Workman, attacked a second train with equal success, scoring three direct hits and firing into the troops. On this one raid of Nos. 25, 16 and 40 Squadrons, fourteen 112-lb. and thirty-four 20-lb. bombs were used.

During October, the German resistance increased and formations were made larger, as many as six machines taking part in the F.E.2b's patrols and raids. Almost every day, in addition to the

AIR STORIES

bombing raids, the Squadron was able to claim several victories. The Wing, and indeed the whole front, had learned to respect and admire the determination of the "25" pilots and observers and, although their machines were becoming obsolete towards the end of the year except for bombing purposes, their indomitable spirit carried them through the winter.

A Change of Tactics

ON November 23rd it became evident that the Germans were beginning to realise the power of large formations, for two flights of F.E.2b's of six each encountered a flight of eight enemy scouts which, in the ensuing combat, were reinforced by twelve more. One E.A. was destroyed and three sent down out of control, while two F.E. pilots were wounded.

These tactics necessitated a change of plans, and to economise in machines and pilots' time it was arranged that work over or near the lines should be done by single machines, intermediate raids should be carried out by two or three aircraft, while flights of six should undertake what was then the long-distance work. Tactics such as these employed by the Tenth Wing contributed greatly to the determined effort we were then making to win and maintain supremacy over the enemy.

In April, the battle for Vimy Ridge began, and the co-operation between No. 25, No. 8 Naval, No. 40 and No. 43 Squadrons was further developed, No. 40, which had by this time been equipped with Nieuports, being given the duty of escorting the F.E.'s on their dangerous low photographic raids.

In June, Major Cherry handed over the command to Major the Hon. O. M. Guest and several of the F.E.2b's were replaced by F.E.2d's, the latter being equipped with 250-h.p. Rolls-Royce engines. Soon afterwards, the newly-developed D.H.4 appeared, and by the end of July the Squadron had made a complete change-over to the latter.

Their duties now changed, for, with its greater climbing power, long range and increased carrying capacity, the D.H.4 was required for long distance work and

photography. The Squadron ceased to be regarded officially as a fighter unit, but, nevertheless, its list of victories over attacking fighters continued to grow.

By October its activities were greatly widened when it was transferred to the 9th Wing, under the direct command of G.H.Q., the Wing being stationed at Boisdingham. Its principal duty under this new command was the bombing of important centres far on the enemy side of the lines. Ledeghem and Beythem stations were amongst the first objectives and raids were carried out by formations of six machines each carrying one 230-lb. or two 112-lb. bombs. As these formations offered very tempting bait for the large flights of Albatroses and Halberstadts, they were frequently accompanied by flights of S.E.5's or Bristol Fighters.

Some idea of the extent of the field of operations of this famous squadron may be gained by the details of the attacks during the battle of Cambrai in November, 1917. The Squadron had been concentrating on the Ypres front during that long-drawn-out battle, but owing to the violent offensive against Cambrai it was required to assist the squadrons on the southern front. No. 25 occasionally used Mont St. Eloi as an intermediate landing ground and from there attacked the principal strategic points in the Cambrai area. On the first day, November 23rd, twenty-two 112-lb. bombs were dropped on Denain and Somain stations. The bad weather that had impeded our aerial work considerably on the initial day of the battle, the 22nd, continued and the raids were performed by D.H.4's working either singly or in pairs. On the 29th, however, the machines were back again in the northern sector, bombing Roulers.

As a result of these varied activities the whole 9th Wing was congratulated by the G.O.C., R.F.C., in a message which ran :

"Please convey to all pilots and observers of the 9th Wing the great opinion I have formed of their work during these recent operations in weather we should have thought two months ago impossible. It shows the utmost gallantry and determination to have carried out the work."

NO. 25 SQUADRON R.F.C.

Patrols at 20,000 Feet

FOR two or three months during the winter of 1917-18 No. 25 Squadron's main duty was photography. At this time, the German Air Force was expanding rapidly and, in view of the impending attack, many new enemy aerodromes were constructed near the lines. No. 25's duty was to find these and to bring back photographs of the developments, from which the probable date of the attack could then be deduced.

It is interesting to record that most of this tedious and "freezing" work was effected at 20,000 feet and over on account of the increased area covered by the camera and the comparative immunity from molestation by hostile aircraft. The effective height of the Albatros and the Halberstadt was about 19,000 feet while the D.H.4 could reach 21,000, a height only exceeded by the French Nieuport, which found its service ceiling at over 22,000 feet.

The bombing recommenced in earnest during March when, just before the German mass attack, the railway communications at Mons, Denain, Cambrai, Aulnoye received special attention, while the German aerodromes at Etreux and Saultain were also attacked. These raids took place from Villers-Bretonneaux aerodrome.

During the great enemy attack, which began on March 21st, the Squadron was standing-by for special jobs: reconnaissance, bombing or photographic reconnaissance. These involved both high and low flying and, strange to relate, during the most hectic part of the battle, from the 21st to the 26th, the flights did not encounter any enemy machines that would tackle them. On the 27th the enemy showed more spirit, and in three fights two E.A. were destroyed and one sent down out of control. These fell to the guns of Second-Lieut. W. H. G. Milnes with Sergeant W. E. Smith, Captain E. Waterlow with Second-Lieut. C. A. Sundy, and Sergeant A. H. Muff with Lieut. J. E. Pugh. Three or four days later Albatroses and D.F.W.'s were again in trouble when Second-Lieut. C. E. H. Allen with Sergeant J. R. Wright, Second-

Lieut. A. E. Hulme with Sergeant A. Remington, and Second-Lieut. S. Jones with Second-Lieut. H. Pullen shot down several more. During this period, despite the dangerous work of bombing and reconnoitring from below 1,000 feet, the Squadron's only casualties were one pilot and an observer missing and two wounded.

In the spring, the Squadron operated from an aerodrome at Ruisseauville, and on May 26th, despite widespread low cloud, a raid by ten machines was ordered on an ammunition dump at Varsennaere. Captain J. E. Pugh was leading the formation which, except for one small gap in the clouds, did not catch sight of the ground before reaching its objective over thirty miles away. The leader's compass course was accurate, for another small gap revealed Varsennaere immediately underneath. The formation then bombed the dump accurately and the Germans, in defence, used the heavy calibre A.A. guns which previously had been rarely encountered. Fire from these was particularly accurate and violent, but the ten D.H.4's returned unscathed to our side of the lines. Visibility was very poor and for various reasons five made forced landings in the difficult country. No one was hurt, however, and next day all the machines returned to the aerodrome intact.

A Daring Reconnaissance Flight

ON May 31st an exceptionally long reconnaissance flight was undertaken by Captain Waterlow and Lieut. Sundy. These officers flew to the German training camp at Beverloo, over a hundred miles from the nearest point of the lines, and returned safely after four hours' flying with 108 photographs of the area.

From June until the end of the war, formations of No. 25 continued their many duties, frequently being attacked by large formations of Fokkers and Halberstadts. On one occasion a large formation of thirty-two fighters failed to attack a small one of D.H.4's, single enemy machines detaching themselves from the main body and attacking in a desultory way.

AIR STORIES

A report by Flight-Lieut. G. M. Lawson put the position clearly :

"Such formations that were met were very large, varying from ten to forty machines. The greater the number the better it was actually for the reconnaissance machine. It generally resulted in a few of the enemy scouts detaching themselves from the formation and making a close attack, the remainder ambling along at a discreet distance. If at our own height the attacking scouts generally split up into two parties; two machines remaining at our height immediately in rear and firing at long range, hoping that we would dive to increase our speed. The remaining numbers would dive down and zoom up under our machine and 'hanging on their props' fire upwards until they almost stalled."

Soon the Germans were on the retreat

and the Squadron moved forward with the rest of the British forces, and when the Armistice came it was stationed on La Brayelle aerodrome. The total casualties incurred were eighteen killed and forty-five wounded (returning to our side of the lines). In addition, forty-seven were missing (reported dead or presumed dead), while another forty-seven were taken prisoners. Sixteen were accidentally killed.

No details are available of how many enemy machines were shot down by the Squadron in the execution of its duties, but an analysis of many of the battles in which the Squadron was engaged shows that the enemy fighters at all times, whether against the F.E.2b's or D.H.4's, suffered severe losses in defending their territory.

HERE'S THE ANSWER

Readers' Questions are invited and should be addressed to AIR STORIES, Tower House, Southampton Street, London, W.C.2. A stamped, addressed envelope must accompany ALL enquiries.

SERVO RUDDERS (F. Royston-Mather, Leeds).

(1) The extension to the main rudder of the Boulton & Paul Overstrand is known as a "servo" rudder, and is an auxiliary control surface making for easier movement of the main rudder by the pilot. (2) There is only one Auxiliary Air Force squadron in the West Riding of Yorkshire, No. 609 (West Riding) (Bomber) Squadron, stationed at Yeadon Aerodrome. (3) Performance and armament of the Hawker Super Fury are secret, but its speed is known to be well in excess of 275 m.p.h. Another type known as the Intermediate Fury, and supplied to various foreign governments, is credited with a top speed of about 250 m.p.h.

AERIAL LIFEBOATS (L. Power, Liverpool). The objection to your ingenious idea for a passenger cabin which could be detached from the main aircraft in case of emergency and descend like a helicopter is that there is no practical type of helicopter yet in being. The nearest approach is the Breguet experimental model which recently made a series of short flights.

GERMAN RECORDS (George Muir, Glasgow).

(1) There is no truth in the old story that the Germans counted a two-seater as two separate victories. (2) The ten greatest aces of the War in the air were Richthofen, 80 victories; Fonck, 75; Mannock, 73; Bishop, 72; Collishaw, 68; Udet, 62; McCudden, 58; McLaren, 54; Barker, 53; Loewenhardt, 53.

NEW EQUIPMENT (R. Martin, Doverdale, and others). No R.A.F. squadrons have yet been re-equipped with the latest, 1936, type aircraft, as sufficient numbers have not yet been built. Quantity supply of these new types should, however, begin very shortly.

SPADS (J. K. Davis, Edmonton, Canada). Spads were so called because they were originally the product of a French firm called the Société Pour Aviation et Ses Dérives. See the connection?

VICTORY SCORES (D. V. Saaler, Pinner, Middlesex). (1) Capt. S. W. Highwood, D.F.C., gained 7 victories (3 'planes and 4 balloons); Lt. C. R. Thompson, D.F.C., gained 6 victories (3 'planes and 3 balloons); Capt. T. F. Hazell, of No. 1 Squadron, scored 41 victories, not 31. He destroyed 31 'planes and 10 balloons. (2) Erich Loewenhardt's score is often given as 56, but official German records show 53, his last victim, a Sopwith Camel, falling on August 9th, 1918. (3) Major P. G. Ducas, of the French Air Service, scored 2 victories.

MODEL PLANS (Joseph Heaps, Birkenhead, Cheshire). A 1/72nd scale blue print of the Italian Macchi Castoldi seaplane M.C.72, holder of the present world's absolute speed record, is obtainable from Skybirds Ltd., 3 Aldermanbury Avenue, E.C.2.

GOTHA BOMBER (D. S. Ellis, Walmer, Kent). Following are the chief dimensions of the 1917-18 type Gotha: span, top plane (with aileron extensions), 77 ft.; lower plane, 71 ft. 9 in.; gap, 7 ft.; chord (top), 7 ft. 6 in.; (lower), 7 ft. 2½ in.; length, 41 ft.; tail-plane span, 13 ft. 6 in. (2) Following are the dimensions of the Friedrichshafen, 1917 type: span (top), 66 ft.; (bottom), 61.2 ft.; chord (max.), 7 ft. 5 in.; (min.), 5 ft. 9 in.; gap, 6 ft. 2 in.; length, 36 ft.; height, 11.7 ft.; tail-plane span, 13 ft.

(More Replies to Readers on page 375).

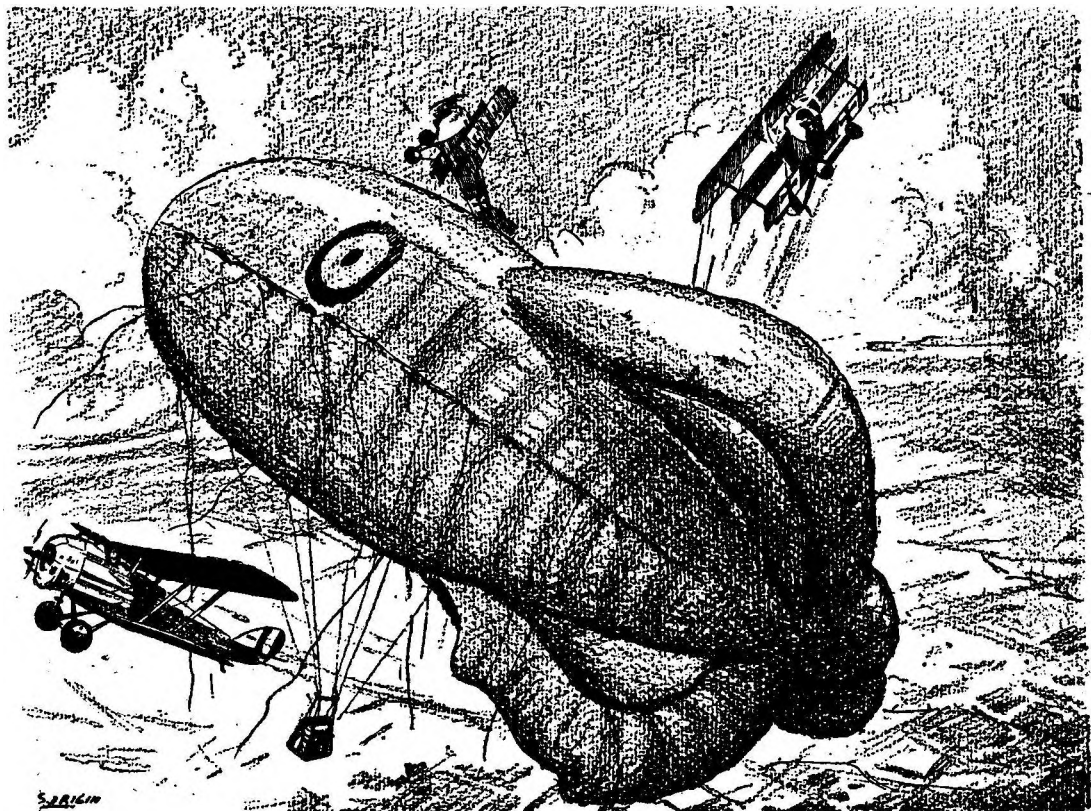

It was a game of hide-and-seek in mid-air, the most extraordinary combat of the War

THE BALLOON-BUSTER

A Combat as Peculiar as Timothy's was likely to have an Unusual Result but, Even So, One Fokker Triplane and One British Balloon is an Extraordinary "Bag" for any One Pilot to Collect

By PHILIP ARNALL

CHAPTER I

Specific Gravity

"**F**AT," said Timothy, leaning back in his chair and exposing the largest expanse of frontage ever seen in the squadron, "is really an aid to climb."

"Are you filled with gas, then?" asked Simpson sarcastically.

"You see," Timothy went on, as if dealing with a scientific subject with cold detachment, "it's not a matter of size, but of specific gravity."

"Specific what?"

"Specific my aunt," put in George Gunne.

"What is specific gravity, anyway?"

"Everybody ought to know what it is," replied Timothy. "It's—it's what you've got, Simpson, but I haven't. You're a nasty little skinny piece of string. I mean you've got simply masses and masses of specific gravity which is as bad as having spots. Now I haven't. All this," he heaved at the lower part of his tunic and caused a huge wave to travel up towards his bulging neck, "is a much higher grade of matter altogether. It's almost entirely

AIR STORIES

free from specific gravity. That's why I can get height quicker than you fellows and make a D.H.5 go up like a lift."

"Specific gravity my aunt," repeated George Gunne. "Who's having what?"

"Mine's a beer," quickly answered Timothy.

"I suppose that's good for your specific gravity, eh?" sneered Simpson.

"On beer one gets sort of aerated and light and frolicsome. One . . ."

But at this point a cushion suddenly put an end to Timothy's remarks. It had been directed with considerable force by Simpson.

"Anyhow," said Simpson before Timothy had time to recover, "I'm ready to race you to twenty thousand feet in a D.H.5 any day."

"You'd cheat," answered Timothy.

"Neither of you'd ever get to twenty thousand feet," said George Gunne. "Besides, why go to all that bother? You've only got to look at the way Timothy's chair's sagging to know the answer. I wonder he can get his zinc off the ground. He's just weight in the round. Look at his chair, I ask you."

Timothy and Simpson were sitting in ingenious chairs, three of which had been made for the mess by Wilson, one of "A" Flight's riggers. Like the bar, they were composed of aeroplane parts, and were really small hammocks. The sides and back were formed by pieces of ash longeron and spruce spar with fabric slung hammock-wise for the seat. At this reference to Timothy's chair, Galbraith began to get interested, and it was he who suggested the fantastic "test" which entertained the mess for the next hour or so and finally led to a sort of height rivalry between Simpson and Timothy which had curious results.

GALBRAITH was a studious type of person; thin, with high-powered glasses. On joining the Royal Flying Corps he had managed to pass the eye-sight test by rapidly memorising the letters on the chart when the examining doctor was not looking. Actually, he was as blind as a bat. But he averred that his blindness helped him in landing

aeroplanes, saying that directly he could see the ground he knew he had to flatten out. If you saw the ground from too far away, he said, you got nervous and misjudged. He was a really fine mathematician, and one of his amusements was to prepare designs of new type aeroplanes which would out-perform the best the Germans had. He also cultivated a pseudo-scientific form of humour which, because it was so different from the commoner boisterous sort, appealed to the mess. When he began peering at Timothy's chair through his glasses, those who knew him guessed he was going to start something.

"Measurement of stress," he said solemnly, "can be made by observing the deflections of fabric of known tensile strength. Now here we have Timothy and Simpson seated on chairs of identical structure, their—ahem!—oil sumps held up, and supported by fabric of identical quality and dimensions. If there is anything in the theory of specific gravity advanced by Timothy, we should be able to observe it in the deflection of the fabric. If Timothy's mass . . ."

"My what?" put in Timothy here, but Galbraith went on: ". . . if Timothy's mass is greater than that of Simpson, the fabric on which he is slung will stretch or give to a greater extent. But wait!"

Galbraith now suddenly began an intensive inspection of Timothy's chair, examining the sides, looking underneath, going round to the back, making profound remarks about stresses and strains and tons per square inch. Timothy looked on without moving. But when Galbraith finally rose and made his momentous announcement, he moved pretty quickly.

"Yes," said Galbraith, "we have the means in these two identical chairs of finally determining the argument between Timothy and Simpson. We can see exactly what is the 'climbability' of the two. Without using up Government petrol unnecessarily—and we know how anxious we are to economise it—we can find out who could get higher in a D.H.5. But we need not measure the

THE BALLOON-BUSTER

deflections. *We shall simply apply the Farnborough method of yield point.*"

"Of what?" asked Timothy, now getting rather perturbed.

"Of yield point. We shall institute a series of tests putting the two chairs under successively greater stresses. We shall so plan that the fabric is more and more heavily loaded, until finally, in one chair or the other, it gives way. The person whose chair lasts longest wins, and is entitled to half a dozen free beers or a couple of cigars according to choice."

"What in hell?" asked Simpson. "I mean, what's the idea? I'm not going to have weights put on my head."

"Like a Nautch girl," said George Gunne irrelevantly.

"Simpson and Timothy, the two competitors," Galbraith explained, "will be raised aloft by appropriate means to successively greater and greater heights, the height being increased by five centimetres at a time. They will be raised in a sitting posture immediately above their chairs and, on a signal, released. They will then descend into their chairs under the force of gravity. The owner of the chair which holds out longest proves himself to have a higher index of 'climbability' . . ."

"And a bruised behind," remarked George Gunne.

"Hi," said Timothy, "none of that. I'm not doing any of this human steam-hammer stuff to please a lot of nit-wits. Nothing doing."

But Simpson suddenly took the other view. "There you are," he said, "the fellow doesn't believe in what he's been telling us. He *knows* he can't climb fast with a carcass the size of the Bank of England. He won't do the test."

"I won't be dropped from heights," protested Timothy. "It makes me giddy."

"Do you keep your brain down there?" asked George Gunne.

But the mess saw in this test some entertainment, so all objections were overruled, and Galbraith planned the details of his scheme. He sent an orderly for two aeroplane safety-belts and two

lengths of wire control cable. A belt was fixed round Timothy and one round Simpson. The cables were led from each belt round the steel tube which acted as a roof girder of the hut. Willing hands hauled on the cables, and both men were raised about a foot above their chairs. Galbraith called out "Ready?" and then "Go!" and the cables were simultaneously released, and both men came down on to their chairs with a bump. Both chairs stood the strain, although Timothy's was noticed to rock violently. The height was increased, and the same procedure followed. Still the chairs held.

Timothy protested that he wasn't going to be dropped from any greater height.

"I mean," he pleaded, "is it right to let officers in one of His Majesty's services settle their differences by being dropped into chairs? Revolvers, yes. Swords, yes. But this uncouth proceeding. I mean, chaps, frankly, it hurts my dignity."

The roar that greeted this remark overbore all opposition, and preparations were made for the next drop. But Timothy insisted on taking another glass of beer first, in order, as he remarked, to reduce his specific gravity to vanishing point and bring him almost to the stage when he would be able to float in mid-air without any material support whatever.

The drop for the next test was alarming, Timothy and Simpson dangling about five feet above their chairs. A hush fell upon the mess as the moment of release drew near, and when Galbraith gave the word "Ready?" there was absolute silence.

"Go!"

The cables were released, there was a terrific thud which shook the entire hut, and then a rending of fabric.

Both Timothy and Simpson had fallen clean through their chairs to the ground, tearing the fabric as they went.

CHAPTER II

Weighty Considerations

FROM the sarcastic way in which he talked, one might almost have thought

AIR STORIES

that Simpson envied Timothy his fat and his good-nature. He never lost an opportunity of jeering at Timothy, and always Timothy replied with good humour and some absurd argument in favour of fatness. After the test of "climbability" in the mess, which had been adjudged a draw, Simpson pressed continually for a race to a fixed height in two D.H.5's, for he believed that he would be able to outclimb Timothy with ease. He was especially confident because he had recently had a finer pitch airscrew fitted, and this was aiding his machine on the climb. He did not say anything to Timothy about the airscrew, and confined himself to stating that the difference between the two machines on climb would be entirely a matter of the pilot's weight.

Timothy, however, was not keen on the climbing contest. He said it would be too cold, and that they had to fly high often enough on patrol without doing it in their spare time. He raised every sort of objection to a climbing race. Simpson, however, at last goaded him to the point of accepting, and it was finally arranged that they should race upwards for a given period, starting side by side. No alterations were to be made to their aeroplanes.

The details had been fixed, and when a fine day came along on which they were free from patrol work until the evening, it was decided to start the race. Timothy ate an enormous breakfast and went out on to the aerodrome.

"You know," he said to his rigger, "I'm not sure that that D.H. of Mr. Simpson's hasn't been faked up somehow."

"He's got a fine pitch prop. on, sir."

"How long has he had that?" Timothy inquired.

"For a fortnight or more, sir," was the reply.

"That's a pity. It's going to be difficult for me to hold him. I'm afraid he'll walk away."

"If we could get the weight down a bit, sir," said the rigger, looking significantly at Timothy's frontal area.

"We've agreed not to alter the aeroplane or engine at all."

"The aeroplane or engine, sir?"

"Yes."

"There's other things beside them, sir."

"Nothing doing. I'm not going on a diet for anybody. Besides, it's too late now."

"I don't mean that, sir. I mean there's something else on the aeroplane."

Timothy looked at his rigger with a slowly gathering smile. Then he gave him a vigorous pat on the back. "My lad," he said, "you've hit it. Nothing's been said about that. We only agreed not to alter aeroplane or engine. Get on to it, my lad. But don't let anyone know you're doing it. Remember it's against orders. If the C.O. heard, I should be in the soup up to the eyelids. We start in half an hour. Whatever happens, keep what you're doing dark."

Timothy raced back to get his kit, with his face beaming as only a fat face can. He looked like a large and lively poached egg.

"I'm going to put it across you in a way you've never heard of before," he called to Simpson. "You wait! 'Climbability!' Hah! You wait! I shall just climb away from you like a lift . . . like a bally elevator. By the time the hour is up I shall be right out of sight above you."

"You talk a lot of hot air," sneered Simpson. "No wonder, either. You're so full of wind, it's got to come out somewhere. But if you think a D.H.5 will lift your tons of flesh up as high as it will lift my featherweight chassis, you're wrong."

WHILE they were talking, Timothy's rigger was working against time. He just succeeded in completing his secret task as the starting moment came. The aeroplanes were wheeled out of their hangars, and Timothy and Simpson climbed into the cockpits. The engines were started. The chocks were drawn away from the wheels. The

THE BALLOON-BUSTER

CHAPTER III

The Balloon-Buster

height race between the heaviest and lightest pilots in the squadron was about to begin.

Just as the two aeroplanes began to taxi out to the leeward side of the aerodrome the C.O. came running towards them waving a message form. He reached Simpson first and, clinging to the side of the machine, holding his cap, and leaning forward over the lower plane towards the cockpit, he spoke to him quickly and incisively. Simpson nodded his head and continued taxiing out. The C.O. then came running to the side of Timothy's machine. He seemed in a desperate hurry.

"You're going on this climb race stunt?" he shouted above the noise of the engine.

"Yes, sir."

"Then I've got something for you to climb for. But you'll have to be smart about it. Every second counts. The observation balloon at Vauvrez has been attacked by a German scout. Men jumped with their parachutes. Cable was severed. The balloon's adrift. It's only just happened. There are battery details in the basket, and they don't want the sausage to go over into Hundland. It's drifting almost parallel with the lines now and climbing rapidly. You and Simpson must catch that balloon somehow and shoot it down. Quick, or you'll be too late. I rely on you. Get that balloon!"

"But, sir," began Timothy, but the C.O. cut him short, waving the message form frantically at him.

"Go on! Don't waste time talking. Vauvrez. Get on with it! Take-off at once!"

"But——"

"Go on, man, for the love of Mike! Don't argue. You've got to catch that balloon and shoot it down. Your darned race can go to hell. The man who gets that balloon wins."

"Yes, sir," said Timothy, his expression changing to one of acute misery. And with the C.O. urgently waving him off, he opened his throttle, taxied out and, with Simpson beside him, took off.

THE two machines kept close together for the first fifteen minutes. Both pilots strove to get the maximum climb. Both went in the direction of Vauvrez. Both engines were all out. Both pilots were studying their flying so as to get the most out of their machines by keeping them at the optimum climbing speed.

Then Timothy began to gain height on Simpson.

At first flying wing-tip to wing-tip the two pilots had been able to look at each other. But now Timothy looked down into Simpson's cockpit, and Simpson looked up at Timothy. It was clear that, for some reason, Timothy had the advantage of Simpson. The difference was not great, but it was there without a doubt. Timothy's machine drew steadily away.

Yet it was identical as to airframe and engine with Simpson's. Simpson had a slightly different airscrew; but that should have aided him, if anything. Otherwise the machines were identical, and Timothy's was carrying about twice the weight of pilot.

Yet Timothy's machine continued to increase the difference in height between them and to climb more and more rapidly compared with the other. By all the rules Timothy ought to have been delighted. The folds of flesh which represented his face ought to have been wreathed and wrinkled in smiles. Yet he was the picture of misery. If Simpson could have seen Timothy's face beneath the goggles, he would have been very surprised indeed.

There was now more than three hundred feet separating the two machines, and every minute the distance increased. Timothy looked down at Simpson. Simpson looked up at Timothy. Vauvrez lay below in the distance. Beyond it, somewhere considerably above them, was the balloon drifting with the light airs parallel with the lines.

One thousand five hundred feet separated the two machines; then two

AIR STORIES

thousand feet. Timothy peered into the distance and suddenly spotted the balloon, still far above ; but obviously within reach if they continued climbing.

Closer and closer to the balloon they came, and greater and greater grew the distance between the two machines. Every hundred feet they went, the climb of Timothy's machine seemed to improve relative to Simpson's. The balloon now loomed quite close. Timothy could see the severed cable hanging below it. He knew he would be within range within three minutes. Then all he had to do was to bring down the balloon, and not only get the thanks of the C.O. and the Wing for a useful piece of work, but also win the climb race against Simpson and give incontrovertible proof of his superior "climbability."

All he would have to do would be to take a steady sight through his Aldis on to the envelope of the balloon and press the trigger of his Vickers gun. Probably a dozen rounds would produce sufficient effect. Yet there was one difficulty in the way ; a serious difficulty.

In order to lighten his machine for the climb race, Timothy's rigger had taken out of it gun, sight, ammunition, ammunition trays and all gun fittings and accessories.

TIMOTHY was now within range of the balloon. He looked at the great sausage with the bitterest hatred. The nearer he got the more loathsome it seemed. If only he had had his gun !

They were now almost on the line, and an A.A. shell-burst, although some way below, showed that the balloon was getting within reach of the German batteries. The British batteries were not shooting at the balloon while there was any chance of its being brought down with machine-gun bullets from an aeroplane. Timothy knew that there was a kink in the line a little farther on, and that here the balloon would be well over Allied territory. So he continued to fly with it, now slightly above it, and as he did so he stirred his brain to frantic

activity to try and devise a method of bringing it down without a gun.

He thought of the stories of people in the early days of the war who had thrown field-glasses at one another ; but he had no field-glasses with him. About the only throwable thing he had was a small pocket knife. It seemed ridiculous to think that he might be able to hit the balloon with a pocket knife. And even if he hit it he wondered if the knife would penetrate the fabric or just fall flat and bounce off.

Then he thought of Simpson, now a good way below. He would eventually reach the height of the balloon and would be able to shoot it down. But Simpson would hardly be able to deny that he, Timothy, had got there first. He would still have won the climb race. It was some slight consolation and he looked down at Simpson. What he saw increased his misery.

From Simpson's engine came successive puffs of smoke, and the D.H.5 was now something like four thousand feet below him. And even as he looked, he saw Simpson turn and go into a glide. Either he had seen that Timothy had reached the balloon and imagined that he would have no difficulty in bringing it down, or else he had engine trouble sufficiently badly to force him to return.

Timothy's position was now particularly trying. He had relied upon Simpson eventually reaching the balloon and bringing it down. Yet now he was left alone with it, utterly powerless to puncture it. The scene was set for an outstanding triumph and, instead, a complete fiasco threatened. But even then the possible extent of that fiasco did not occur to him. He merely saw a lost opportunity and was unconscious of the fate that was awaiting him.

He circled round the balloon, feeling like a starving man who sees food kept just out of reach. It was the most tantalising position imaginable, and he circled closer and closer with vague ideas passing through his mind of trying to gash the balloon's side with his airscrew, or of trying to puncture it

THE BALLOON-BUSTER

with an undercarriage wheel. But he realised that either manœuvre would almost certainly mean that he would bring himself down in addition to the balloon.

Although he was now getting extremely cold, for he had reduced his flying clothing to a minimum in order to cut weight, he continued to try and devise some method of bringing the balloon down, hoping that, in the last resort, it might start descending of its own accord. Timothy was tenacious and was not readily discouraged. He still felt that if he thought hard enough about the problem he would be able to hit upon some way of reaching out and puncturing that balloon envelope and bringing it down without endangering his own machine.

"There must be," he said to himself, "some way of doing it."

Then it occurred to him that other aerodromes might have been warned, and that other machines might even then be coming up. He would remain with the balloon and circle around it, unless it started to drift more towards German territory. He peered down to try and see if any other aeroplane was climbing up from below. It would be better to see the balloon brought down by somebody else than to have to give up the problem entirely.

Then a faint smile spread over his fat face. He listened intently. Yes. Above the sound of his engine, he distinctly heard the noise of a brief burst of machine-gun fire.

"Somebody's coming up and keeping his gun warm," he thought. "I'll stand by until the good work is done." He peered round, but could not see the other aeroplane. Yet his assumption that there was another machine approaching with the object of shooting down the balloon was correct. All doubts on this point were settled in the next few seconds.

For with a noise like the day of judgment three Fokker triplanes, bearing the German crosses on their wings, rushed down upon Timothy with guns rattling.

CHAPTER IV

Hide and Seek

AT any time it is awkward for a single aeroplane to be attacked by three enemy aeroplanes. But when that single aeroplane is without a gun or any means of returning fire, the position may be regarded as rather more than awkward.

Timothy slammed his D.H.5 into a turn and spun upon his attackers as if he was about to shoot at them. And in fact he did succeed in getting one triplane in a position which, had he had a gun, would have allowed him to get in a good burst . . . had he had a gun. But the other two came upon him from another direction, and again he saw tracer apparently lacing his machine.

He turned quickly. The triplane also turned to keep out of the way and, so doing, went into the first turn of a spin as a result of the rarefied air at that height, which gave small lift to its wings. At any other moment Timothy would have been amused at the caution with which the three triplanes treated him; for they did not know that he had no gun and were anxious never to get in his sights. Indeed, it appeared that the triplane pilots were becoming puzzled and anxious about the absence of fire from Timothy's D.H.5. They seemed to think that a trap was being laid for them, and became warier and warier. Probably it was this that gave Timothy a few moments of grace, for had the truth dawned upon the German pilots they must have had Timothy down in flames in a few seconds.

But, hearing no return fire, the triplane pilots began wondering what it was all about and looking around the sky for reinforcements, and wondering if they were being lured into a trap laid by the perfidious English. So their attacks were not so assured as they might otherwise have been, and by violent manœuvring Timothy managed to evade them and frequently to gain a firing position himself, only to remember with mounting rage that he had no gun with which to take advantage of it.

After the fight had been engaged for

AIR STORIES

some time, however, and the triplane pilots saw no reinforcements arriving, they began to believe that the English pilot had suffered a gun stoppage. So they became more daring and more certain in their methods.

One of them sought to get on Timothy's tail and to stay there. And Timothy had the greatest difficulty in shaking him off. Bullets whistled past him, and he manœuvred with desperation in order to evade his attacker's fire. Meanwhile, the other two triplanes were watching things from one side and above. They noticed that their friend had failed to bring Timothy down, but they also noticed that no reinforcements came for the Englishman, and that, although they were slightly on the Allied side of the lines, there was no sign of any mysterious trap laid for the especial benefit of honest, unsuspecting German pilots.

So their courage rose. And when their comrade broke off because his fire failed to take effect upon the lone English machine they came down upon it with enthusiasm.

Now a D.H.5 had many notable features. It could dive like no other machine that has ever been invented before or since. It could go down exactly like a bomb and keep on going in a way that would have torn the wings off a Camel or even an S.E. But it could not maintain height near its ceiling in a dog-fight. That was agreed by all who knew the machine. Its backward stagger may or may not have had something to do with it. That is a matter for the technologists. But the pilots were unanimous in the belief, first, that though it could dive, a D.H.5 could not hold height even so well as a Pup and, second, that, at height, it demanded especial care in manœuvring if it were not to fall into a spin.

So when Timothy was attacked with real confidence by two of the German triplanes, he was almost sure that the only defence available to him was prayer. Yet Timothy was not a religious person. So perhaps it was as well that just at that moment he noticed the balloon,

which he had come especially to bring down. The fight had not moved very far away from it.

TIMOTHY saw in that balloon a method of escape. And when the two triplanes, confident that there was no trap and that they had at last found what every German pilot longed for, an English machine alone with a stopped gun, came down on Timothy with the intention of shooting him into small pieces, Timothy went straight for the balloon. It was about the same height as they were, so that going towards it did not necessitate his breaking the first rule of air fighting, never to lose height.

He flew close to the side of the balloon and then turned sharply so as to put the balloon between himself and his attackers. In fact, he used the balloon as a sort of smoke screen to prevent his own movements from being observed. At one moment, when he heard the guns going from the other side of the balloon, it almost seemed as if it were a real protection to him, although actually the German bullets ripped through the fabric like a hot knife through butter.

His manœuvre had a success beyond his expectations. The German pilots, again puzzled, had to pull out of their dives, and Timothy, coming up on the far side of the balloon, had the pleasure of watching them zooming and trying to find him. If only he had had a gun he might have been able to shoot both of them down. But as it was, he was forced to watch them helplessly as they soared overhead.

This extraordinary game of hide and seek, with the balloon as a sort of screen between Timothy and his opponents, seemed to go on for an age. And every time the Germans dived upon him he heard the machine-guns rattling, and every time he went round to the other side of the balloon and, even though they continued to fire, prevented them from getting a true sight. It was a game of hide and seek in mid-air, the most extraordinary combat of the war, and

THE BALLOON-BUSTER

what the outcome would have been no one can tell had not a slight error on Timothy's part produced an instantaneous change in the situation.

Timothy, while making one of his rapid dodges behind the balloon, caught a fleeting glimpse out of the corner of his eye of another aeroplane. At last, he thought, some other British machine is coming up to the rescue. He turned towards it.

But he was mistaken. And when he saw that it was in fact the third of the triplanes which for some reason had momentarily broken off the combat, he was not only surprised, but also frightened. For he was now far from his balloon protection.

At first he hoped that he would have time to get back and continue the game of hide and seek. And he observed that the balloon, which, at the time when the Germans launched their first attack, had drifted close to the lines, had now drifted back again and was fairly well over the Allied side. If he could but continue his game of hide and seek, using the balloon as a protection, the Germans would be sure to break off the combat in time, for they were notoriously averse to getting too far over the Allied side of the lines.

So directly Timothy saw that the machine which he had gone to join was in fact the third triplane, he turned quickly and made back for the balloon. But he was too late. In every sense the fat was in the fire.

The two other German pilots saw that Timothy had, as it were, broken cover, and they were on to him like a flash. They came down mercilessly, with guns flaming.

They rushed upon him so that he was powerless to turn out of their line of sight. If he swung right they followed his movement and poured metal upon him. If he turned left they closed up and hosed him with an almost continuous stream of fire and lead. He was trapped, and trapped far from his only protection. Metal hailed upon him. The roar and rattle of the concussions smote his ears. The sky reeled before his eyes.

DESPERATELY Timothy measured the distance between himself and the balloon and sought to return to it. But it was no use. The two Germans were bent upon destroying him. They hung on to him like ferrets. He twisted and turned in vain. They knew somehow that he was powerless to hit back. They knew they had lured him away from his protective balloon. They knew that, barring the unexpected, they would add another German victory to the credit of their squadron. They knew that nothing could live long in that storm of steel. It was a great moment for them as they tore in to complete their work, much as the officer in charge places his revolver to the temples of the victim of the firing squad in order to make sure that there is no life left in him.

The two triplanes, immediately joined by the third one, dived on the wretched unarmed Timothy. He heard the crescendo roar of their guns. He saw himself outmanœuvred, outnumbered and outweighed in fire power. Then the words of the experienced D.S.O. pilot who had instructed him in war flying came back to him, a voice which seemed to call to him and penetrate that inferno of lead and fire.

"In a dog-fight never lose height. Climb all the time. *Never lose height.*"

He pulled the nose of his D.H.5 up and strained it up to the sky. But the three triplanes, profiting by their initial advantage in height, were upon him. They swept down mercilessly, guns rattling.

For one fraction of a second panic seized Timothy. He rejected the advice of that old and experienced pilot.

He put the nose of the D.H.5 down, down, down.

It was vertical.

It was plunging straight towards the ground in a direct fall. It was diving as only a D.H.5 can dive.

It was screaming earthwards in a shattering fall from the sky.

It was dropping with an acceleration which seemed to spell disaster.

It was breaking the first rule of air fighting.

AIR STORIES

And the three triplane pilots saw it go into that dive. And they, too, recalled the words of their German fighting instructors.

"If the enemy dives away, you will him follow; for he is your butcher's meat."

Exultantly they dived in pursuit. It was now only a matter of moments before they would be able to add one more to their list of victories.

But occasionally rules do not apply. Occasionally they are made to be broken.

The lightly-loaded triplanes could not go earthwards so fast as the backward-staggered D.H.5.

The triplanes dived and dived and dived. Yet they did not get any nearer the meteor-like D.H.5. The D.H.5 drew away from them in that terrible earthward fall like an express train from a goods train. It fell out of the sky, and nothing in the world could have held it. Timothy sat with clenched teeth and stick thrust forward, seeing the earth rush up at him.

One triplane pilot determined to do something about it. He pressed over his machine until it was vertical, and then slightly over the vertical. He opened his engine throttle. There was a sudden reversal of load. A flutter of fabric. A puff of smoke. And the triplane which had been tearing down to deal the *coup de grace* became a few floating fragments of wood and fabric with its pilot, a black bundle, falling dreadfully to his death.

The other triplane pilots saw this and gently, very gently, extricated their machines from the dive. They had decided that they had done enough for the day. They disengaged and turned for home.

CHAPTER V

A Matter of Credit

THREE-QUARTERS of an hour later Timothy landed at his home aerodrome. There were quite a number of people out on the aerodrome waiting for him. Directly his machine lost speed and began to taxi in, George Gunne

rushed out and leaped on the step behind the rear plane.

"Good boy," he called. "You turned the gas on all right. Both well on our side. You can have your choice of doughnuts or jam tarts for tea."

"What is that?" yelled Timothy above the noise of the engine.

"I say both of 'em, balloon and triplane—or bits of 'em—came down on our side. It was good work. The A.A. told us all about it. That gasbag was as full of holes as a fishing net. Great work."

Timothy was puzzled.

He taxied in and climbed out of the machine, Simpson coming up as he did so. The C.O. also arrived at the double.

"Good work!" he said. "I was very bucked you got the balloon down, Timothy, but it was a great show to shoot that triplane to pieces as well."

Timothy was still a little puzzled, but gradually it dawned on him that he was being congratulated on having achieved his first "victory." Had he bowed his head in modest silence all might have been well; but like so many fat people, Timothy had a conscience, or at any rate bits of one. The promptings of that conscience were now insistent, and with every word of congratulation that the assembling members of the squadron shouted at him, they became more insistent. A confession was called for; but there was one thing against it. That matter of disobedience to orders in having the gun and ammunition taken out and the question of whether his rigger would be implicated. Also he did not want to give away the method that had enabled him to outclimb Simpson.

"I—I think, sir, I ought to explain," stammered Timothy. "There's something I ought to tell you about it. It wasn't exactly what you thought."

"Why, how d'you mean?" asked the C.O.

"I—I did not shoot at the balloon at all, sir."

"Did not shoot at . . . but, my dear boy, it's riddled with bullet holes."

"You must be a magnificent misser,"

THE BALLOON-BUSTER

interposed George Gunne ; but Timothy, feeling increasingly noble and self-righteous, went on :

"No. I didn't shoot at the balloon. I don't deserve any credit or congratulations. I was attacked by the three triplanes when I got near it, and I used it as a sort of shield."

"A what ?"

"A shield."

"Why, was this one of those cast-iron balloons ?" asked George Gunne, affecting sudden intense interest.

"I mean I revved round it and they revved round it, and we both revved round it with them shooting all the time."

"Here we go round the mulberry bush sort of thing, eh ?" suggested George Gunne, until the C.O. gave him a nasty look.

"I think I see what happened," he said. "You mean you dodged behind the balloon so that they wouldn't get a true sight on you, and it was *their* bullets which went through the envelope ?"

"Yes, sir."

THE C.O. looked relieved. After all, his squadron would get the credit. "Well, there's nothing in that," he said. "I shall still credit you with having brought the balloon down. After all, it was one of our own, and if you hadn't played up the Huns you wouldn't have got either the gasbag or the triplane. Shooting that triplane down was far more important than getting the balloon."

Timothy was on the point of explaining that he had not even shot at the

triplane ; but it occurred to him that he might, without stretching the point, take the credit for having brought that down. It was his action that caused the triplane to break up, even though it may not have been his gunfire. Morally, he was entitled to claim that he had brought the triplane down. So he said no more. And probably to this day nothing more would have been said had not Simpson, who had been looking with interest at the front of Timothy's aeroplane, come forward with the sarcastic remark :

"By the way, Timothy. You noticed how I outclimbed you before my engine went dud ?"

"You outclimbed me ?" said Timothy indignantly. "Why, I was . . ." he stopped short. Simpson had glanced significantly over towards the front of Timothy's aeroplane, at the place where the gun ought to have been, and then towards the C.O.

"Er. Oh, yes, rather. You were slightly above me . . ." he agreed, inwardly raging at this barefaced black-mail.

Simpson gave him a bang on the back.

"Never mind, Timothy," he said, "at least you've got the triplane to console you" ; and then added in a voice so low that only Timothy heard him, "not to mention the distinction of bringing down an E.A. with the fewest number of bullets on record."

"A veritable triumph of obesity," Galbraith was saying as they all turned towards the mess, and was rather proud of it until George Gunne capped it with a casual "*Per ardua ad abdomen.*"

"AIR STORIES" CORRESPONDENCE CLUB

READERS wishing to be put into touch with correspondents interested in Aviation have only to follow this simple procedure:—

WRITE the usual letter you would first send to a new friend with whom you had never before corresponded—mentioning in the letter your age, particular interests in aviation and hobbies.

SEND this letter to us, together with a stamped, self-addressed envelope. If you have any special wishes regarding the correspondent you want, such as whether he should be resident in the British Isles or some particular Dominion, or interested in

some particular hobby, mention these facts in a separate note accompanying your letter.

From the letters at our disposal, we then select one from a reader whose age and interests are in common with your own and send it to you, at the same time forwarding your own letter to this particular reader. If there is no suitable correspondent waiting at the time of receiving your letter, we will retain it until one is available.

READERS living abroad must enclose a postal reply coupon instead of a stamped envelope.

All letters should be addressed to "Correspondent," AIR STORIES, Tower House, Southampton Street, Strand, London, W.C.2.

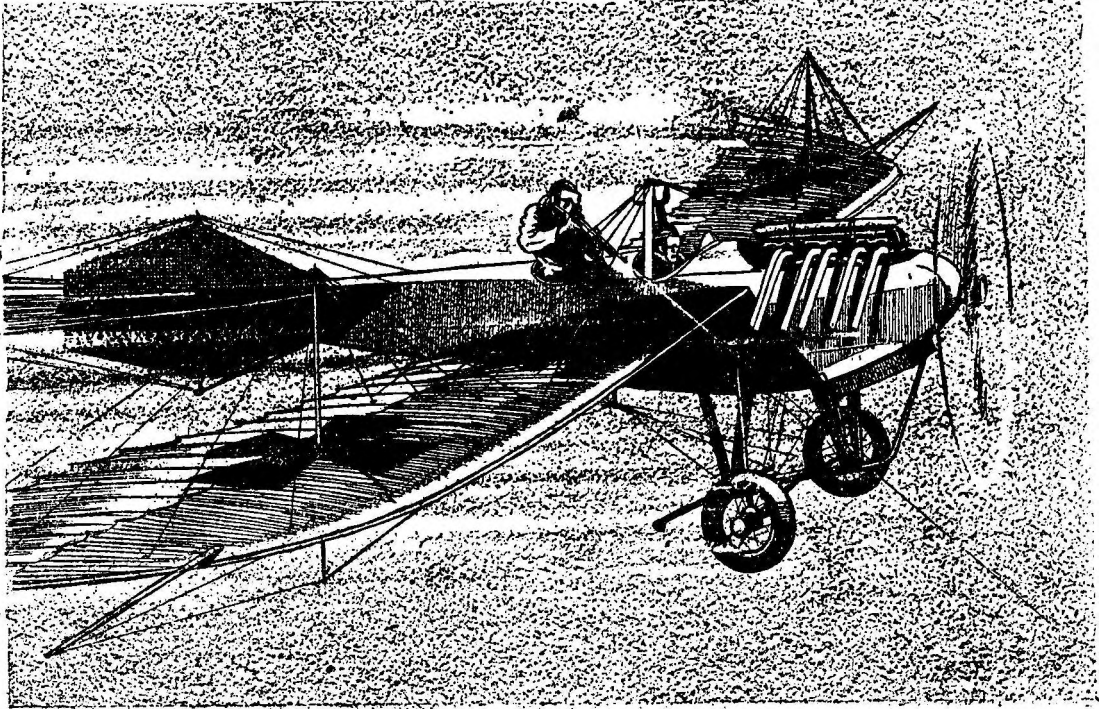

The observer of the Taube was taking careful aim at him with a carbine . . .

EARLY "BIRDMEN"

The General Thought that Nothing was Impossible for his "Birdmen" and Lieut. Jimmy Stirling, who disliked being called a "Birdman" almost as much as being Fired On by his Own Side, Suffered both to Prove that the General was Right

CHAPTER I

According to Plan

"I DUNNO what to do about it," protested Lieutenant James Stirling aggrievedly. "I was up at a good height—nearly fifteen hundred feet—but every blasted Tommy must have pooped off at me. I got three bullets in one wing and another in the elevator. Bad enough when the Germans pot at one, but when our fellows take a hand at it, well . . ."

"It's the ruddy limit," agreed his friend, one Captain Longridge. "It's not as if our 'buses were slow or anything like that. My old Blériot hops along at a

good sixty in still air and your Avro must do about as well. Seems to me our lads are getting too damned good with their rifles."

"We've got to do something about it," persisted Stirling. "Heaven only knows how long this ruddy retreat . . ."

"Steady, old man," grinned Longridge. "Retirement according to plan, you mean."

"All right, have it your own way," agreed Stirling, filling his pipe. "Retirement, if you like. But, whatever it is, if it lasts much longer I'm going to get fed up. Five new landing-grounds in eight days, isn't it? You get off to do a show and when you've done your

A Dramatic Story of the Early Days of the War in the Air

By MAJOR L. S. METFORD

Late of No. 13 Squadron, R.F.C.

chukker and come back to fill up your tank, you find the P.B.I. leggin' it across where you took-off from."

"I know," nodded the other sympathetically, "and you have to push on with about a cupful of petrol in your tank and look out for the new 'drome with the aforesaid P.B.I. taking pot-shots at the 'bus as you flit over 'em. Matter of fact, I've had rather a bright thought," he added, his grey eyes wrinkling at the corners. "How'd it be if we painted a distinguishing mark on the underside of one of our wings—say a 'B' for British or something

like that which they can see from the ground?"

"Quite an idea," grinned Stirling doubtfully, "but I bet they'd think it was 'B' for Bull and try and score one. Seriously though, we ought to do something, but I vote for a Union Jack. Can't mistake that, you know."

Longridge nodded. "Something in that. Let's stroll along and see what the Major thinks of it."

It was the end of August, 1914. The four squadrons of the R.F.C. and the single squadron of the R.N.A.S. already in France were doing their utmost to

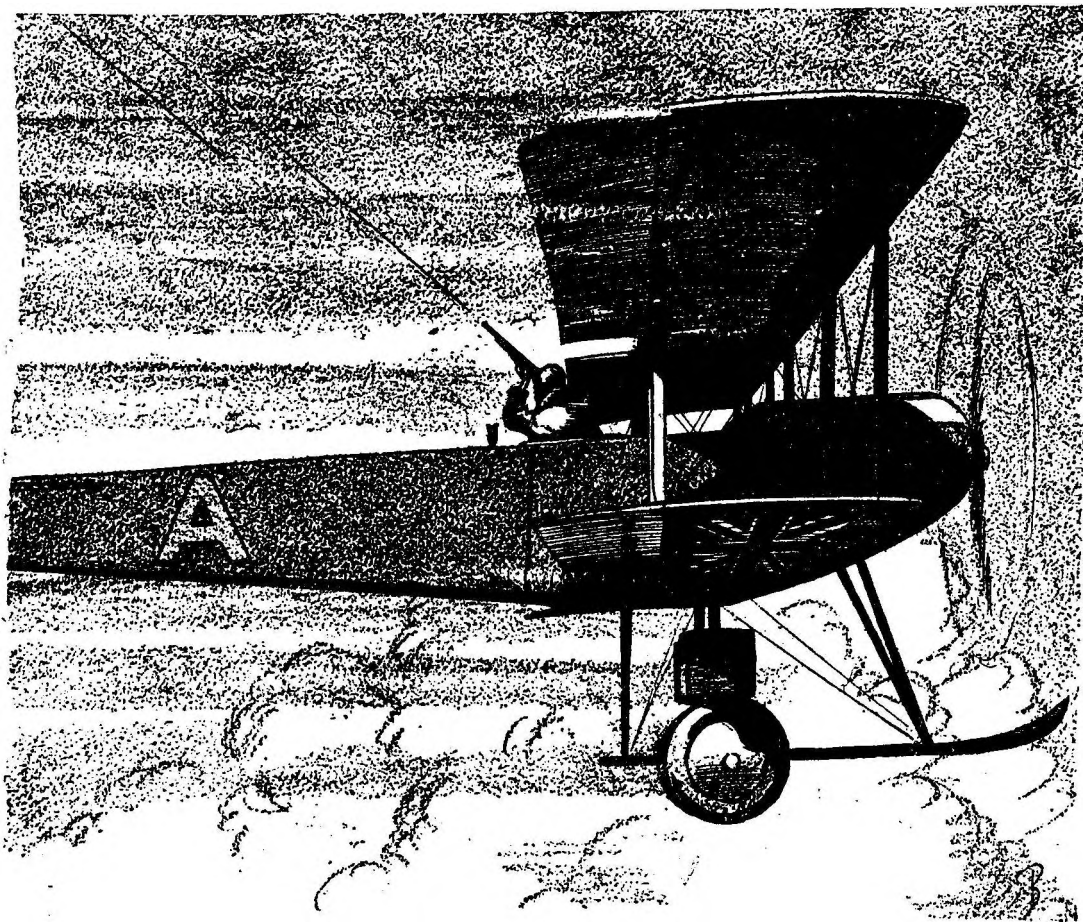

... he grabbed his own Winchester, but the Avro gave a sudden lurch ...

AIR STORIES

discover von Kluck's intentions.* At the moment it seemed that he was trying a gigantic outflanking movement which, if successful, would mean nothing less than the total annihilation of the British Expeditionary Force.

The retreat from Mons was in full swing, except that at the time it was not referred to as a retreat, but, as Longridge had just reminded Stirling, "a retirement according to plan."

Retreat or retirement, it was all the same in effect, but that it was orderly instead of a demoralised rout was due in the greatest measure to the new eyes of the Army.

Unarmed, save for service revolvers; inexperienced, with nothing to aid them but memories of the autumn manoeuvres of two years, when they were frankly experimental; with no cameras save their own private and mostly unsuitable ones, nevertheless they carried on, and day by day G.H.Q. was learning to place ever more reliance on their reports.

Therefore, to some extent, the "retirement according to plan" was a correct statement, though the plans were made hurriedly at an hour's notice, and subject to revision before they were carried out.

THE two inseparables found their commanding officer seated under an ancient apple tree, poring over an O.S. map.

"Come into the office, you chaps," he grinned, pointing to a couple of boxes lying on the ground. "They're pretty wonky, but if you sit down gently they'll probably be up to your weight. What's on your mind?"

Captain Longridge told him, studying the toes of his muddy field boots the while, his long legs sticking out before him.

"I think it has the germ of an idea, Major," he concluded. "What do you think about it yourself?"

"Splendid. Quite a bright thought,

in fact. I'll ring up the Flight sheds and . . ." He broke off suddenly and laughed a shade self-consciously, whilst the others grinned appreciatively.

"At least, I would if I had a telephone," he amended.

"And if we had a Flight shed," added Longridge. "We aren't at Netheravon now, sir."

"Surprisin' what a lot can happen in a month, isn't it, sir?" supplemented Lieutenant Stirling. "A month ago . . ."

But Major Fielding was not listening, and Stirling broke off short. The squadron commander flicked over a few papers meditatively, then looked up.

"I went over to see the General this morning," he remarked. "Matter of fact, the old gentleman sent for me. That last report of yours, Longridge—you know, up by Charleroi—has given the Staff something to think about. They haven't exactly got the wind-up, you know, or anything like that, but things look—well, they look pretty dam' bad, and the General wants the fullest information obtainable about von Kluck's movements."

"Well, he's gettin' it, isn't he, sir?" This from Longridge.

"He is and he isn't. He says it's too hit and miss. Mind you, I'm not complaining. You fellows are doin' dam' well, but the old boy isn't exactly technical. Never been up in his life and doesn't want to. A month ago he thought aircraft were more or less toys. Now he's had a complete change of front and thinks nothing's impossible for the R.F.C."

"Very complimentary an' all that," drawled Stirling with a grin, "but a trifle inaccurate."

"Mm. I told him so, but he's so enthusiastic about us 'birdmen' as he persists in calling us . . ."

"'Birdmen'—ugh—terrible," groaned Stirling.

"Agreed!" laughed Fielding, "but there it is. Now this is what we've got to do. The General says we've got to keep accurate tab on their advance. Well, we're doing it, and it's by far our

* These were Nos. 2, 3, 4 and 5 Squadrons, R.F.C. and an R.N.A.S. Squadron led by Wing Commander C. R. Samson.—EDITOR'S NOTE.

EARLY "BIRDMEN"

CHAPTER II

The Enemy Advances

most important job at the moment. From now on you two and Winram and Salisbury'll be on that job and nothing else. You, Longridge, will detail them so that as soon as one's seen coming in, the next'll take-off."

"And if one doesn't come back, sir?" suggested the Flight Commander meaningly.

"Give 'em a time limit, and if they aren't back by the time you set 'em, send out the next without waiting for him. If you get stuck over anything let me know. Follow the idea?"

"Rather, sir. Kind of relay race."

"Mm. By the way, I got fired on yesterday by a feller in a Taube of sorts. He had an observer on board. He was busy sketching our positions when I ran alongside him. I grinned at him—you know the way one does—and kind of shooed him off, but this observer johnny picked up a carbine and took a pot shot at me. Dam' cheek. I know it isn't exactly cricket, but you'd better tell your fellows to take up a revolver or an automatic with 'em in future. It's a bad principle to start, of course, but the Germans have only themselves to blame. They began it—the silly blighters."

"Good Lord, Major," expostulated Longridge, "it's all we can do to fly our ruddy kites without tryin' any funny business as well."

"I know," grinned Fielding. "Whenever I try to make a note of anything on my pad, the dam' kite takes charge and tries to loop the loop. However, tell 'em to do the best they can, will you? Cheerio!"

"I've got a sporting rifle," Stirling remarked as the two pilots saluted and went out of the "office." "Winchester repeater—thirty-two special. Think I'll take that up, Skipper. I'll get the blacksmith to make a rest for it on the top longeron at a convenient height. Then if I get excited or the 'bus tries some funny stunt, I shan't drop it overboard."

"Good idea, but don't let him make it too heavy, that's all," was Longridge's reply, and thus was invented what was probably the first R.F.C. gun-mounting.

THAT afternoon Captain Longridge, a four-foot Union Jack painted in the shape of a shield on the left wing of his 50-h.p. Blériot monoplane, scuttled into the air with a clanging of telescopic undercarriage tubes, and headed in the direction of Charleroi.

Half an hour later, just as the finishing touches were being given to the Jack on the underside of the lower plane of Jimmy Stirling's Avro, he returned.

"Broken inlet valve spring," he grunted as he climbed out. "Wonder she didn't catch fire. Flight Sergeant!"

"Sir?"

"Hear what I said?"

"Yessir. I'll get a couple of men on the job right away. Number six cylinder, sir," he added quickly, running his hand expertly over the engine. "That's the coldest one."

"See anything, Skipper?" asked Stirling interestedly, watching his engine-fitter squirt raw petrol into the exhaust valves. "My turn next."

"Dashed rummy thing," said Longridge ruminatingly. "The beggars seem to be changing direction towards the south-east. Can't be sure, mind you. Engine was missing so badly I had my work cut out to keep her in the air at all. See what you can make of it, Jimmy. I'll warn Winram to stand by. He'll leave at . . ." he glanced at his wrist watch ". . . at four pip emma. Righto. Hop off, old man."

Stirling climbed into the cockpit of the Avro and called "Switch off!"

"Switch off, sir!" repeated the mechanic and swung the prop. over backwards half a dozen times. The raw petrol streamed from the exhaust valves and the man stood aside.

"Contact, sir."

"Contact," replied Stirling, switching on. The mechanic, standing with straddled legs, with the curving centre skid between his feet, pulled the rotary over compression.

The Gnome kicked back, wavered an instant and then barked in syncopated

AIR STORIES

time. Then, as Stirling ducked his head in and fiddled with the fine adjustment, the sound changed and the engine roared steadily whilst mechanics, hanging on to the fuselage, their overalls fluttering in the dense cloud of blue castor-oil fumes, watched for the signal to let go.

A couple of minutes later Stirling blipped the switch, lowered his goggles over his eyes and looked around him. Then he waved an arm. The men with the chock cords jerked them away in unison, whilst those at the fuselage stepped back smartly as the Avro ran down the field.

"Nice take-off," commented Longridge to the Flight Sergeant standing beside him. "Hope he doesn't have engine trouble. Those Gnôme obturateurs are the very devil. How's Mr. Winram's machine?"

"All correct, sir. Just finishing the wing markings."

"Good. Have her warmed up at five minutes to four, please."

"Very good, sir," and Flight Sergeant Dale trotted off to check up the dihedral on Winram's single-seater Blériot.

Longridge hurried away towards the workshop lorry standing in the lane. Its radiator, as were those of all the other transport in those troublous days, was pointing towards the west, ready to move away at a moment's notice. As he reached it, he heard a whistle blown and the Sergeant-Major came running from the direction of the C.O.'s office.

"What's up, Sar'-Major?" enquired Longridge as the warrant officer halted and saluted.

"Orders to retire immediately, sir," the N.C.O. replied, and hurried past him.

"Damn!" remarked Longridge, and broke into a run.

"ANOTHER retirement, Major?" Longridge asked as, a little out of breath, he reached the old apple tree under which Fielding was sitting.

The Major nodded without looking up. He was busy packing documents into a couple of wooden cases. The Squadron's Daimler car was standing

nearby with the driver filling up the tank from a spare petrol can.

"Put these into the back, Thornton, and wait for me," called Fielding when he had finished.

The driver straightened his back and came over for them.

"Where to now, Major?" asked Longridge.

The other slung his map-case round and pointed through its squared celluloid cover.

"E in Sorrieux," he replied shortly.

They stood and listened for a few moments, heads aslant, eyes screwed up in the direction of Le Cateau.

Above the deep and perpetual accompaniment of field guns could be heard a sound which, though audible all the morning, was now definitely more pronounced—the crackle of rifle fire.

"Pretty close, sir," muttered Longridge.

"Too close," replied Fielding.

Down in the lane beneath them another whistle sounded, followed immediately by the rattle of the lorry engines as their drivers swung the heavy starting handles. Then, with a crashing of gears, the big, coloured vehicles began to lumber on their way.

"I'm leaving a light tender for the mechanics," said Fielding. "I'm going ahead to the next landing-ground and'll be back again in an hour—if there's time. I'd like you to stay here and keep things going, but don't cut it too fine. If I'm not back it'll be because I'm delayed by some darn thing or other. Cheerio!"

Longridge saluted and hurried off. He didn't like to hear rifle fire quite so close, and it was growing in intensity every minute. In one corner of the landing-field was a Henry Farman. The undercarriage had been smashed in a rough landing the day before, and mechanics were feverishly trying to repair the damage, but without proper spares and with no workshops it was an almost impossible job.

"How're you getting on with it?" demanded Longridge of the pilot who, in overalls, was working with the mechanics.

EARLY "BIRDMEN"

The pilot looked up with a frown on his grease-smudged face.

"None too well, Skipper. It's quite a job, and those dam' tubes buckle every time we take the jack out. Don't think she'll ever take the weight."

Longridge went down on his knees and crawled under the lower wing. Then he backed out again.

"Too bad to lose the old 'bus, but I'm afraid you're right. You've got about an hour before we push off. If you can't get her going by then, set fire to her."

He hurried off to watch the progress of other minor repairs to the four 'planes left behind, giving the necessary orders for the evacuation when the time should come. And all the time the rattle of rifle fire was coming closer and closer. Now and again a German shell went thundering overhead with a noise like an express train, as they shelled the back areas. He looked at his watch. Five to four. Simultaneously, the engine of Winram's Blériot was started up, and he smiled approvingly at Sergeant Dale's promptness. Five minutes later, with Lieutenant Winram in the pilot's seat, it took-off. As it did so, six shells erupted almost in line in the very middle of the aerodrome. Instinctively, Longridge threw himself flat on the ground, whilst flying fragments rained about him.

Then he jumped to his feet and raced across the field.

"Take-off at once!" he shouted, "and follow me. Sergeant Dale?"

"Sir?" The N.C.O. rose to his feet, dabbing at a cut on his forehead where a shell splinter had grazed him.

"Get these machines started," he called, racing on. "Marshall," he ordered as he reached the Henry Farman, "set fire to your 'bus if you haven't got her repaired. Have you?"

"No, sir."

"All right, set her alight; then take charge of the light tenders and drive to the E in Sorrieux. Fall in the men as soon as we're off the ground, and see you've got 'em all."

Ten minutes later, circling for altitude,

Longridge caught sight of little groups of khaki-clad infantry retiring stubbornly in open order across the wheat-fields, whilst away to their right batteries of horse artillery came galloping hell-for-leather to take up new positions in the shelter of clumps of trees.

CHAPTER III

Ungentlemanly Behaviour

"BY JOVE," muttered Jimmy Stirling, staring fascinated over the side of his Avro; "this is the life; the real thing. Laffan's Plain isn't in it with this. Cripes!" he ejaculated, glancing at the terrain spread out beneath him, "old Longridge was right. They are changing direction. And it looks as if they're moving south-east just as he said. What a mob! What a hell of a mob! 'Strewth; the ruddy country's fairly crawling with 'em. Bet they're making for the Oise."

He flew on, determined the General should have no reason to criticise his report as "hit-and-miss" on this occasion.

Flying the Avro with one hand, he scribbled rapidly with the other, plastering his large scale map with letters corresponding to his written notes. Now and again the pencil flew from his fingers and hung by its string from his wrist whilst he wrestled with his controls.

"Whoa, Emma? Come up there. Not so much of this funny business, darn you. Hold up. Hold up, there. That's better. Now then. Where's that pencil? Where were we? Oh, yes. There's Le Cateau, so St. Quentin must be over there. Right."

Out in front of him the 50-horse power Gnôme was buzzing away regularly. The rev-counter showed 1,250 and the castor oil pulsed steadily in its little glass gauge. From time to time large calibre shells hurtled past him. He saw one pass over him—coming from behind—and instinctively ducked. The little 'plane, badly underpowered, bucked and dived in the partial vacuum caused by the passage of the shell, but Jimmy held

AIR STORIES

on and finally got the Avro under control again.

Later, still busy with his scribbling, he became aware of a droning sound that grew gradually louder and louder above the buzzing of his Gnome. He looked about him, but saw nothing to account for it. Suddenly he bethought him of the rear and looked over his shoulder.

"Golly," he grinned, "there's old Fritzie again. What a racket his old 'bus kicks up."

Unconcernedly he turned back to his note-taking.

Then a shadow gradually crept across his right lower plane. He looked aside and scowled, shaking his fist in the face of the pilot of the Mars D.F.W. which was now flying by his side.

The German pilot waved his hand and shook his head sternly. Jimmy could see he was shouting at him, but he heard no word.

It was a monoplane of the Taube type. He had met it before, as had others in the Squadron. It had a 120 h.p. Austro-Daimler engine under the bonnet and a car-type radiator. "Fritzie" they called it, a term which included also the pilot and his observer seated behind him.

Then, above the sound of the engine, Stirling suddenly heard a slight "crack."

Surprised, and wondering what it was, he looked back, and saw the observer taking careful aim at him with a carbine. He saw the stock kick back against the man's cheek as he pressed the trigger.

"Crack!"

"The dirty dog!" he shouted, more in sorrow than in anger.

Dropping his pencil to the end of its string, he caught at the butt of his Winchester, hanging in the hastily-contrived fitting the blacksmith had fashioned, and took hurried aim.

The two machines were now about a hundred feet apart, and the man in the rear seat looked an easy target. He squeezed the trigger, but the Avro gave a sudden lurch at the moment and he had to drop the rifle.

When he had the machine steadied again the other 'plane was not in sight,

but a minute or two later Stirling picked it up some distance below him. Promptly he dived down after it.

The other saw him coming and banked aside, the observer putting in a quick shot as the Avro passed. Stirling, thoroughly annoyed by this time, kept after him and fired a couple more rounds without apparent effect. Then, with an ironical wave of the hand, the pilot climbed above him and made off towards the north.

BUT Stirling was not yet defeated. He managed to coax an extra twenty-five revolutions out of the engine at the risk of overheating, and climbed after the Hun. He had a new idea and saw no reason why it shouldn't work.

He could see the muzzle of the carbine projecting over the side of the fuselage, but of pilot and observer he could see nothing. Therefore he stayed where he was, shrewdly arguing that if he could not see them, neither could they see him.

Gradually the space between the two machines lessened until not more than fifty vertical feet separated them. Then, leaning sideways, Stirling cuddled the butt of the Winchester against his cheek and squeezed the trigger. Leaving go of the stick, he ejected the empty case and another round automatically fed itself into the breech. Twice—thrice he repeated the manœuvre and then dropped the rifle and grabbed at the whipping stick as the Avro skidded away from under him. By the time he had steadied her and looked about him, the German 'plane was nowhere to be seen.

Looking carefully in all directions he at last made it out, far below; so far, indeed, that it seemed almost on the ground.

"Wonder what's up?" he thought. "Surely I couldn't have winged him. What luck if I did though—poor blighter. By Jove! How goes the time?" He glanced at his watch. "Phew! Quarter past four. Ought to have been back long before this. I'll be out of petrol in a few minutes. Wonder how much I've got left?"

EARLY "BIRDMEN"



The puzzled N.C.O. came to a halt, his bayonet touching Stirling's chest

AIR STORIES

He looked anxiously at the gauge, but nothing showed, and he cursed himself for his forgetfulness.

"Darn that fellow in the Mars," he exclaimed. "If it hadn't been for him, I'd have been home by now. What'd he want to butt in for, anyway? I wasn't interferin' with him."

He was still well within the territory over which the Germans were advancing so victoriously when his engine began to misfire. His heart skipped a couple of beats as he juggled frantically with the fine adjustment of the carburettor. But it was no use. The engine picked up for a few moments, it is true, then spluttered out completely.

He switched off.

From his height of about fifteen hundred feet, which was now decreasing with disconcerting speed, he looked down with a queer feeling of helplessness.

He had had forced landings before—plenty of them. As a matter of fact, he had been rather keen on them at home. There seemed usually to be a fair-sized country house somewhere in the vicinity where he was invariably made welcome by adoring young things whilst mechanics and spare parts—telephoned for somewhat leisurely, he it remarked—came down from the Squadron by tender to make the necessary repairs.

It had all been rather fun, but now—now it was vastly different. He seemed to be in another world altogether; a world with no gracious country houses so far as he could see; a world peopled by men in grey uniforms and cloth-covered spiked helmets who shot at him at every opportunity.

No; he didn't like it: not at all. He felt that from now on his usual enthusiasm for pheasant shooting would wane decidedly. He'd leave that alone in future—if he had any future—which seemed unlikely at the moment. For the first time in his life he was seeing things from the pheasants' point of view.

REPEATEDLY, and with a growing feeling almost of panic, he looked beneath him for somewhere to land—

somewhere free from this grey-clad horde of riflemen.

But no clear space could he see. There seemed to be troops everywhere—grey wave upon grey wave—advancing in open order at first and then in solid phalanges farther to the rear; the roads and lanes black with transport and artillery limbers. In the distance the smoke and flame from burning villages billowed upwards into the summer skies.

Then, by chance, he caught sight of a long and narrow strip of stubble between two streams running to a point at their junction and gradually widening out. It appeared deserted. Evidently, he decided hurriedly, the Germans saw no object in fording two streams when by diverging somewhat one would suffice.

Another thing he noticed was a Taubetype monoplane gliding in to a landing on that same spot. Instantly he recognised it as the Mars he had fired on.

Ruddering over, he aimed for the point of the long and narrow triangle, stretching his glide to the utmost. Watching the other 'plane, he saw it land, run round in a half circle and slow to a standstill at the very edge of the stream.

As he dropped lower and lower, little strips of fabric flicked up from his wings. He heard a metallic clang as a bullet hit his engine and ricocheted off. "Hate to be hit by a ricochet," he thought. "Makes such a beastly hole."

Looking overside, he saw men kneeling and firing up at him, the sunlight glinting dully on the blue barrels of their rifles. He badly wanted to zig-zag to put them off, but knew it would be as much as he could do to get in with a straight glide, and so intent was he on his problem that he scarcely felt the pain when a bullet cut through the flesh of his right thigh. Almost impersonally he glanced down at the torn bedford cord of his breeches and the spreading crimson stain. Then he riveted his eyes on the ground beneath.

As it rushed up to meet him, he discovered that the margin of the twin streams was covered with sedge and rushes, and wondered how soft the

EARLY "BIRDMEN"

ground would be. He knew now that he would land short, and he was worried as to whether it would be better to pull the pin from his belt or leave it fastened. Fortunately, he decided on the latter course, and probably saved himself a broken neck when, a few seconds later, his wheels struck the ground and stuck in the mud. The curved central skid broke off short, and the machine stood upright with the engine buried in the swampy ground.

Stirling was flung forward with his forehead against the cowling when the belt cord broke with the impact, whilst stars of a greater magnitude than he had ever imagined danced before his eyes.

With his head buzzing like a circular saw and his nose cut by his broken goggles which, forgetting all instructions, he had omitted in the stress of the moment to throw away, he struggled from the cockpit and climbed out. Sinking to his knees in the mud and water, he scrambled up the sloping bank and lay flat amongst the rushes. Then, remembering something, he waded back to his machine and struck a match. It took some seconds before the fabric caught, and he cursed the delay, but he knew it must be done.

CHAPTER IV

Down in Hunland

WHEN the flames had a firm hold on the Avro, Stirling clambered ashore again and lay hidden whilst bullets zipped and sang round his hiding place. Crawling flat on his stomach, he made his way along the margin of the stream, then, after a hundred yards or so of this slow and laborious method of advance, he rose to his knees and looked warily about him.

At no great distance from him he made out the German 'plane standing derelict on the grass. Watching it closely through the parted rushes, he saw no signs of life, and started crawling towards it. His leg was becoming painful now and he tied his handkerchief tightly round it to stop the flow of blood.

Some ten minutes later he had almost reached the Mars, keeping the radiator between him and its occupants. Then he rose to his feet and limped towards it. Reaching the side of the fuselage, he looked in, revolver in hand.

But he saw at once it was not needed. The observer was quite dead, slumped against the side of the padded cockpit, while the pilot, though conscious, was too badly wounded to offer any resistance.

Stirling looked about him quickly and saw, to his dismay, that a dozen or so German infantrymen were fording the stream on the opposite side of the field.

There was no time to waste if the desperate chance he was about to take was to succeed.

Climbing astride the fuselage, he placed his hands under the observer's shoulders and managed to dump him over the side and into the rushes unseen by the troops advancing on the opposite side of the 'plane. Then, climbing into the blood-spattered cockpit, he pulled the pilot into the rear seat and dropped to the ground.

By this time the infantrymen, coming at a fast double, were within hailing distance, and the N.C.O. in charge shouted to him to surrender.

"*Kommen Sie hier!*" he shouted sternly. "*Hilfen Sie mir. Mein Beobachter ist verwundet!*"

The N.C.O. was barely fifty feet away by this time and his men were just behind him. Stirling could plainly see the look of surprise on his blond features at being addressed thus in his own language. He came on, his rifle at the "ready," without slackening speed. Never, Stirling decided, had he been in such a difficult situation. There was nothing for it, however, but to try and bluff it out.

"Quick!" he ordered in German. "Can you swing a propeller?"

The N.C.O. was plainly puzzled. He came to a halt, the bayonet on his rifle touching Stirling's chest.

"*Der Engländer . . .*" he blurted, breathless after his run. "*Ich . . .*"

"He is dead," Stirling cut in with a

AIR STORIES

contemptuous glance over his shoulder in the direction of the wrecked Avro. "I killed him."

Then he swore at the man in fluent German. A year at Heidelberg, he realised with sudden pleasure, supplied one with a wonderful vocabulary of vituperation.

"*Achtung!*" he ordered sternly. "Since when does a corporal confront an officer in this manner?"

The N.C.O. began to stammer, growing red in the face. The men behind him, gathered in a semi-circle, looked at each other, completely mystified, and began to mutter amongst themselves.

"Silence!" roared Stirling, taking a step towards them in a threatening manner. "Another word and I will report you for insubordination. Silence, and stand to attention there!"

He whirled on the N.C.O., fishing in his flying coat for his note-book. "Your name and regiment?"

By this time the thoroughly bewildered corporal was standing like a ramrod; a posture immediately adopted by his men—all looking straight before them.

"Felix Schuster, corporal of the 119th Bavarian Infantry, Herr—Herr . . ."

"Herr Hauptmann," completed Stirling instantly, deciding he deserved a step or two in the way of promotion in the circumstances.

"Herr Hauptmann," replied the German submissively. "I trust the Herr Hauptmann will not report me. It is very difficult. Never before have we seen one of our aviator officers so close. The uniform was unknown to us, mein Herr."

"Well, make a note of it for future use," Stirling said sternly. "And don't make stupid mistakes again. I repeat—can you swing a propeller?"

"*Nein—nein, Herr Hauptmann.*" The N.C.O. shook his head decisively. "Never have I seen such a machine before."

"See if any of your men can, then," Stirling ordered.

The N.C.O. relayed the question, but the men all protested their complete ignorance of the subject.

"Very well then," announced Stirling

with decision, "detail one of them at once and I will show him how."

Corporal Schuster turned smartly on his heel and faced his squad.

"Johann Taussig," he ordered, "hand over your rifle to Zimmermann and step forward."

Trembling visibly, Johann did as he was told.

"*Sehr gut,*" announced Stirling. "Come here. It will not hurt you. If you do it well, I shall recommend you for a reward. Take off your *pickelhaube* or it may be sucked into the propeller. Hand it to me. Now, when I call 'Contact,' pull down hard on this wooden club. This way. See?"

"*Ja wohl, Herr Hauptmann. Ich verstehe.* It will not harm me, you say?" he implored in a tremulous voice that came strangely from a fifteen-stone giant of six-feet-two.

"*Gar nichts.* Not at all. The engine will then start and you will step aside. That is all. And if you do it well I will write to your Herr Kolonel personally. His name?"

"Der Herr Kolonel von Starhein, Herr Hauptmann," replied the man instantly.

"Good. I shall remember. Wait for the word."

STIRLING made for the cockpit and clambered in, ducking his head quickly beneath the shelter of the windscreen to hide the grin of satisfaction which would persist in trying to belie the sternness of his tones.

"This," he muttered, fiddling with the controls which he was delighted to find appeared undamaged, "is where I take a tip from the woodpecker. He also uses his head when he works."

Then he slid the throttle open a trifle and moved the switch. It was not marked "ON" and "OFF" and there was nothing to denote in which position it was at the moment. He trusted to luck, however, that the engine had stopped in response to the switch and not through any other cause. In this event it evidently worked in the same direction that was universal in the

EARLY "BIRDMEN"

R.F.C. machines, that is forward for "ON."

He was about to call for contact when he heard a voice behind him. "*Wasser ! Wasser !*" it pleaded hoarsely. "I die of thirst."

Stirling hesitated, torn between anxiety to escape before suspicions were aroused in the minds of the hoodwinked soldiery and pity for the man he had so seriously wounded. In the end pity won ; and it was almost his undoing for, forgetting for the moment his assumed nationality, he called to the nearest man in English : "Hi, you . . ." and stopped aghast. Quickly he continued in German : "*Holen Sie etwas zutrinken !*"

And as two men instantly ran forward unslinging their water-bottles, he thanked Lady Luck that his slip had gone unnoticed.

"I have wine," smiled one ingratiatingly. "Champagne wine, looted from a chateau of these French pig-dogs. Take it, Herr Hauptmann, for the brave aviator."

Leaning forward, Stirling took it from the man and held it to the greying lips of the wounded pilot, who swallowed greedily, then coughed. "*Ganz gut,*" he muttered. "*Danke schön, mein Freund.*"

Stirling tossed the water-bottle back to the soldier.

"A good act," he said. "May you be rewarded. Contact !"

The giant tugged fearfully at the propeller and sprang aside with surprising agility as the Austro-Daimler, still warm, kicked forward.

A few minutes later, followed by the admiring eyes of the troops, who forgot their iron discipline sufficiently to wave their helmets at the departing wonder, Stirling tore down the narrow strip of stubble and rose into the air.

The machine seemed very nose-heavy to his touch and extremely hard on the controls, but he put it down to his total inexperience with this type of machine. However, looking down beside him, he saw an aluminium lever which he thought did not seem to have any particular job in life, and moved it tentatively.

The nose dropped at once so, somewhat

startled, he pulled it the other way. Immediately the nose came up and the fore and aft controls became much lighter. Looking backwards, he moved it again and found that the angle of incidence of the tail plane was variable and obviously connected with the lever by his side.

"Something new all the time," he grinned cheerfully. "Quite a scheme. If I ever manage to get the 'bus home, this might be a new idea for the R.A.F.* crowd to adopt."

He pushed the Mars upwards and headed for home ; that is, he headed for the place he had left a couple of hours or so before. But when, in due course, he reached it, he failed, at first, to recognise it, and was greeted with a salvo of shots from the British infantry who were deploying across the aerodrome. Then, seeing some buildings he thought he remembered, he circled the field once or twice and even dropped a few hundred feet lower to make more sure.

It was then that he spotted the blackened steel framework of what had once been a Henry Farman, and realised what must have happened.

"If they haven't gone and flitted again," he swore. "Poor old Marshall had to leave his beloved Henry behind after all, did he? Rotten luck. He loved that old tub. Wonder where they've gone now," he reflected.

Looking about him carefully, he decided the best thing he could do was to carry on in the same direction and trust to luck.

And it was pure luck that, some quarter of an hour later, prompted him to glance away to the left. There, with the sun shining on its satiny wings, he saw a 'plane taking-off above a clump of trees and promptly ruddered over towards it.

TEN minutes later he landed clumsily on all four wheels and splintered his propeller against an inconvenient tree.

Seeing that people armed with rifles

* R.A.F. = The Royal Aircraft Factory at Farnborough where the B.E., R.E. and S.E. types were originally built.—EDITOR'S NOTE

AIR STORIES

were running towards him, he decided to stay where he was until they reached him, especially since his leg, growing more and more painful, hurt like the devil when he tried to move it from the rudder-bar.

"All right," he grinned, holding both hands above his head as the foremost, who happened to be Captain Longridge, covered him with a revolver. "*Kamerad*, Skipper. I surrender. Better have a look at the poor bloke in the dicky-seat. He's probably passed out by now."

"Good Lord, Jimmy," gasped Longridge, behind whom an interested group of mechanics was rapidly collecting. "Where the blazes did you gather this in?"

"Quite a yarn, Skipper," Stirling smiled, wincing as he tried to move from his cramped quarters. "Tell you later. Here," he called, diving into the cockpit. "Catch!"

"What's this?" demanded Longridge, neatly fielding the *pickelhaube*. "A German helmet. Where'd you get that?"

"Same place. That's local colour, presented to me by a friend of mine. Lend a hand, Skipper, will you? I got nicked in the leg. Spoilt a perfectly good pair of Moss's best cords."

"Jove! Why didn't you say so before?" said Longridge with sudden concern, "instead of playing the giddy goat up there? Is it serious, old lad?"

"Don't think so, but I'm bleedin' like a stuck pig."

Carefully they lowered him to the ground, where he stood hanging on to the side of the fuselage and testing his foot on the grass. Suddenly he went white, muttered: "Sorry, Skipper—I think I'm—going—to . . ." and fell into Longridge's arms.

They carried him between them and laid him on a camp cot in an outhouse by the edge of the field whilst one ran hurriedly for the M.O. But before the doctor arrived a few minutes later, Stirling had come round again.

"Damned silly—thing—to—do, Skipper," he muttered shamefacedly as he saw Longridge looking down at him,

greatly worried. "Never—did—a thing like that—be—before. H-how's the feller I—brought along?"

Longridge nodded towards the opposite corner, and Stirling, lifting his head, saw a still form lying on the floor covered with an Army blanket.

He raised questioning eyebrows, and Longridge shook his head.

"Not yet, but he doesn't look any too good. Where's that M.O.?"

He came in at that moment, followed by the squadron commander, who had just returned from H.Q.

"Well, well, well," greeted the M.O., rubbing his hands together professionally. "And what's the matter with you?"

"Nothing," replied Stirling briefly. "Go and have a look at that chap in the corner, there's a sportsman. I'm all right."

CHAPTER V

Circumstantial Evidence

ABOUT an hour later Stirling, with his leg neatly bandaged, a bulging haversack between his feet and with Major Fielding standing beside him, was seated in the presence of General Heppenstall.

Since this was the first time he had been seated in such close proximity to such a distinguished officer he felt acutely embarrassed. He also felt somewhat dizzy, but whether it was from the effects of the flesh wound or from the four or five quick Scotches he had downed in the interim, he was not quite sure. He rather hoped it was the latter, as he would probably recover from it the sooner.

"Most interesting," the General was saying, "but are you certain—absolutely certain?"

"Quite, sir," Stirling replied. "The whole of von Kluck's army—as far as I could see, there were five army corps and a corps of cavalry—are wheeling south-east in the general direction of the Oise."

"Astounding," breathed the General, turning to his G.S.O.I., standing beside him. "Never heard of such a thing in

EARLY "BIRDMEN"

my life. The dam' fools! Heavens alive, man!" he spluttered, jumping up and staring at an enormous wall-map, "if they carry on like that the French Fifth and Sixth Armies'll have 'em cooked as sure as God made little apples."

He turned back quickly to the table and stared at Stirling.

"And you're quite positive, young man?"

"Quite, sir," replied Stirling, a trifle thickly. The room seemed a little unsteady. Not himself, of course—just the room.

"I wish we knew what regiments von Kluck has with the First Army, sir," put in Colonel Ransom, his Chief-of-Staff. "If we could just find out one of 'em, sir, we might get a pretty good idea of what sort of material we are up against."

"Quite impossible, Ransom. Quite impossible. At the height at which these young men fly they could never discover that. I can tell you that myself, although I admit freely I am a little non-technical where these er—birdmen are concerned."

Stirling groaned slightly. He could not help it.

"Birdmen. Ugh! God forbid!" he muttered.

The General looked up.

"What was that?" he interrogated.

"Er—nothing, sir—nothing at all," Stirling answered promptly, realising he had spoken his thoughts aloud quite unintentionally. To cover his confusion, he took a cigarette from his case, tapped it on his thumb-nail and lit it, inhaling gratefully.

Then remembering suddenly that young subalterns, even when the bearers of interesting tidings, do not smoke unbidden in the presence of General Officers Commanding, he crushed it between his fingers and stepped on it.

Then he looked up at Major Fielding standing beside him. He was saying something to the grey-haired gentleman in the red tabs sitting at the opposite side of the table. He could scarcely believe his ears. Here was good old Fielding, modest old Fielding, actually "bukhing."

"Nothing," he heard him say, "is impossible to the Flying Corps, sir."

Stirling felt the Squadron Commander's hand on his shoulder, pinching him gently, and took his cue.

"Well, there are the 119th Bavarians, sir, commanded by Colonel von Starhein," he remarked casually.

"Where did you learn that, young man?" The General was leaning forward on the table, gazing at him as if fascinated.

"Private Johann Taussig told me this afternoon, sir," Stirling grinned.

"And who, in Heaven's name, may he be?"

"He's a friend of mine, sir. He pulled my prop. over for me, and gave me this." He bent down and extracted the *pickelhaube* from his haversack and placed it on the paper-littered table with a polite bow. "As a keepsake, sir."

FOR ten very long seconds the General stared from the cloth-covered helmet to Stirling and from Stirling back again, like a rabbit confronted by a snake.

Then he smashed his clenched fist on the table.

"Either you are mad, young man, or I am. I think it's you."

Then, and not till then, did Major Fielding come to the rescue, repeating all Stirling had told him about his adventurous reconnaissance during the drive from the temporary landing-field to G.H.Q., and illustrating his story with the end of a pencil tapping on the map pinned to the wall. Nor did the story lose anything in the telling.

"Well, I'll be damned," remarked the General, when the recital was ended. "Well, I'll be damned. In future I'll believe nothing is impossible to you birdmen."

They turned from the map suddenly as something thudded on the floor behind them, accompanied by a smothered groan.

Together they picked Stirling up from the recumbent position into which he had quietly slid.

"Birdmen—ugh—terrible," he muttered sleepily as they laid him gently on a couch.

AIR BOOKS

Reviews of the
Latest Books
on Aviation

BACK FROM THE DEAD

"Flight to Hell": By Hans Bertram: Hamish Hamilton: 10s. 6d.

THIS is the thrilling story of an eventful flight by a young German aviator, Hans Bertram, who set out to make the first seaplane flight from Europe to Australia, reached his objective and then, with his companion, vanished from the face of the earth.

The flight was made in a single-engined Junkers W.35 seaplane, and, with a crew of four, the Dutch East Indies were safely reached after a journey rich in incident. At Java, two of the crew were dropped and Bertram and his engineer took-off on the most dangerous stage of the tour—a five-hours' night flight over the Timor Sea to Port Darwin. From that moment they disappeared. Aeroplanes and ships searched for them in vain, and, after several weeks had passed, they were finally given up for lost.

Forty days after their disappearance they were found by aborigines on the desolate northern coast of Australia, without food or water. And at the end of fifty-three days they were brought back to civilisation after an experience which few men could have known and survived. The horrors which they endured during their long imprisonment in the "hell" of the Australian bush make a harrowing tale, while the unravelling of the strange circumstances by which they were found is a first-class mystery story in itself.

Later, the seaplane was salvaged and, undaunted by their experience, Bertram and his companion substituted wheels for floats, resumed their flight round Australia, and finally flew back to Berlin in six and a half days to complete 35,000 miles of adventurous flying and to celebrate an escape as amazing as any in the history of long-distance flying.

SMITHY'S OWN STORY

"My Flying Life": By Sir Charles Kingsford-Smith: With a Preface by Geoffrey Rawson: Melrose: 16s.

WITH the disappearance and presumed death of Sir Charles Kingsford-Smith in November, 1935, whilst engaged on a flight from England to Australia, there passed a man whom pilots of every nation acknowledged ungrudgingly as the world's greatest airman. Such recognition is not lightly made, and its justification in full is to be found in this stirring record of Kingsford-Smith's flying life, prepared under his personal supervision and from the diaries and papers that he left.

As with many other famous airmen of to-day, Kingsford-Smith's introduction to aviation was due to the Great War. Joining the Australian Expeditionary Force in 1915, at the age of eighteen, he transferred the following year to the R.F.C., and was flying Spads with No. 23 Squadron until a wound sent him back to England to act as an instructor until the Armistice. The War over, Kingsford-Smith could not forsake the air, and, buying a couple of aged D.H. 6's, he set up a joy-

riding and air-taxi business with two of his war-time companions. The business was short-lived and Kingsford-Smith records with grim humour the hard struggle that followed; of an attempt to make the first England-Australia flight in a Blackburn Kangaroo that was banned by the Australian Premier as too hazardous, of still more perilous moments as a film stunt pilot and wing-walker, and, ultimate degradation, of a temporary job as a "Flying Scarecrow" to keep the birds from damaging a rice crop.

For nine years Kingsford-Smith wrested a precarious livelihood from the air until, in 1927, he met Charles Ulm and began a partnership that was destined to make aviation history. The first flight across the Pacific soon followed, and thereafter the story of Kingsford-Smith's life is closely linked with that of his famous Fokker monoplane "Southern Cross," now a treasured possession of the Australian National Museum. With candour and humour he tells the stirring "inside" stories of his numerous great flights around the world, his repeated record-breaking flights between England and Australia and the strange adventure when he and his crew came very near to death in the wilds of north-west Australia. The story concludes with a vivid description of his trans-Tasman flights, and there can be few more dramatic records in the annals of aviation than the wireless operator's log of the "Southern Cross's" amazing escape from that dreaded sea, once described by Kingsford-Smith as "the world's worst bit of ocean."

A great book this, worthy of the great-hearted and very gallant airman whose memory it perpetuates.

A SAVAGE SATIRE

"Race the Sun": By Dale Collins: Constable & Co.: 7s. 6d.

THE de-bunking of senseless record-breaking flights made by publicity-seeking adventurers was long overdue, and in "Race the Sun" Mr. Collins has done the trick to perfection. His story opens with the first attempt at a lower stratosphere flight from England to Australia, and records the rivalry of two of Britain's most famous pilots, Sir Rex Masters, who was a garage hand until the naughty but irresistible Lady Charmian found another use for him, and Kay Connolly, who was an Australian shopgirl until she decided to forget a broken romance in conquering the air.

How these two, first in deadly rivalry and later in a partnership of no less deadly enmity, set out to gain and hold the limelight of fame is brilliantly told. Newspaper clippings, cables and letters keep the movement brisk, and fine descriptive passages alternate with dialogue that is as audacious as it is often witty.

Adventure, too, there is in plenty in the vivid accounts of eventful transatlantic and world flights, but it is primarily as a satire, savage, yet with the stuff of truth in it, that this very modern novel will be remembered by all who have ever been behind the scenes of the record-flight racket.

Magnificent

CORONATION SOUVENIR

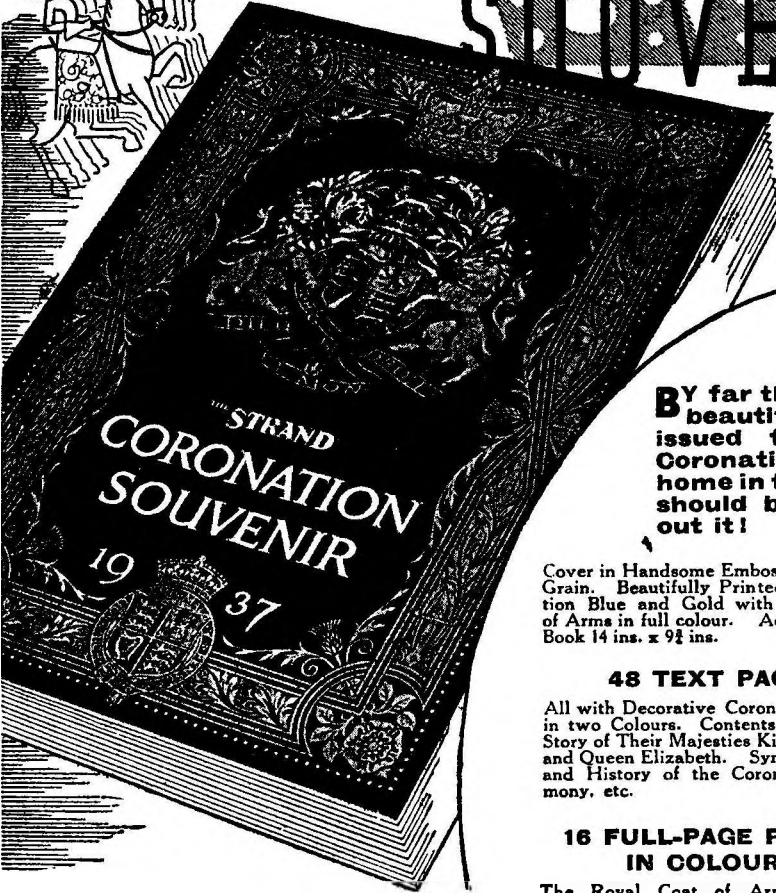
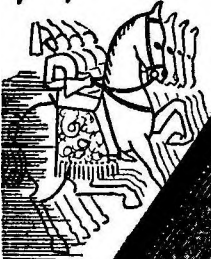

A Lavish
and Historic
Production

BY far the most beautiful book issued for the Coronation! No home in the land should be without it!

Cover in Handsome Embossed Leather-Grain. Beautifully Printed in Coronation Blue and Gold with Royal Coat of Arms in full colour. Actual Size of Book 14 ins. x 9½ ins.

48 TEXT PAGES

All with Decorative Coronation Border in two Colours. Contents include Life Story of Their Majesties King George VI and Queen Elizabeth. Symbolic Detail and History of the Coronation Ceremony, etc.

16 FULL-PAGE PLATES IN COLOURS

The Royal Coat of Arms—Their Gracious Majesties King George VI and Queen Elizabeth—T.R.H. The Princesses Elizabeth and Margaret Rose—The First Oblation: King Charles I—The Coronation of Queen Elizabeth—Proclamation of King George VI's Accession—The King's Champion—Westminster Abbey: The High Altar—Queen Mary—The Coronation Banquet of King Henry VIII—The Crown Jewels, etc.

The Strand

CORONATION SOUVENIR

GET YOUR COPY TO-DAY 2/6

Of all Newsagents and Bookstalls, or by post 3/- (3/2 abroad) from the Publisher, George Newnes, Ltd., Tower House, Southampton Street, Strand, London, W.C.2

George Newnes, Ltd.

FREE BEAUTIFUL ART PLATE
OF FAMOUS AIRCRAFT
with every issue

These beautiful free presentation plates will make excellent and most suitable wall decoration for the Club Room or Model Maker's Workshop.

Order your copy to-day

AERO MODELLER

The Foremost Model Aviation Magazine **6D.**
From all Bookstalls and Newsagents

● Specimen copy gladly sent on request. ● Monthly
24/6 Dean St., Fetter Lane, London E.C.4.

**FREE SERVICE
FOR READERS**

READERS requiring information concerning goods or services advertised in AIR STORIES should give names of Advertisers from whom particulars are desired. Any number of names may be included and we will obtain for you catalogues, lists, and any other information you may be wanting. **THERE IS NO CHARGE FOR THIS SERVICE.**

Readers desiring particulars from a number of Advertisers will, by this method, save time and postage. Halfpenny stamp only is required if your envelope is left unsealed. If any Advertiser stipulates that stamps or postal orders are necessary before samples or catalogues are sent, please enclose the necessary amount with your instructions. You are cordially invited to make full use of this Service.

Post this to

ADVERT. SERVICE DEPT.,
AIR STORIES,
8-11 SOUTHAMPTON STREET,
STRAND, W.C.2

Please obtain and send to me particulars from the Advertisers in your April issue whose names I give on list attached.

Advertiser	Page No.	Information Required
------------	----------	----------------------

Attach sheet of paper, with particulars, and your name and address (written in BLOCK letters), with date, to this announcement.

I. C. S.
can mean to you



The trade revival has brought Trained Men into greater demand than ever before. Only through training can you succeed in life. I.C.S. Training can strengthen your earning power and place you in line for promotion. It has helped tens of thousands who to-day are occupying good positions and earning good salaries.

Established 46 years ago, the International Correspondence Schools are by far the largest institution in the world teaching by post. I.C.S. Courses cover almost every branch of business and industry, and many professions. The student studies when and where he wishes. The fees are moderate and can be paid by easy instalments.

If you are interested in success for yourself, you should be interested in an I.C.S. Course. Write for our free advice or use the attached coupon.

COUPON FOR FREE BOOKLET

**INTERNATIONAL CORRESPONDENCE
SCHOOLS LTD., DEPT. 65, INTERNATIONAL
BUILDINGS, KINGSWAY, LONDON, W.C.2**

Without cost or obligation, please send me your booklet of information about the Courses I have marked X

BUSINESS AND GENERAL

- | | |
|---------------------|-----------------------|
| Accountancy | Journalism |
| Advertising | Salesmanship |
| Book-keeping | Scientific Management |
| Commercial Art | Secretarial Work |
| Commercial Training | Shorthand-Typewriting |
| French and Spanish | Short-Story Writing |
| General Education | Window Dressing |
| Insurance | Works Management |

TECHNICAL AND INDUSTRIAL

- | | |
|--------------------------|-------------------------|
| Aeronautical Engineering | Mechanical Engineering |
| Agriculture | Mining |
| Air Conditioning | Motor Engineering |
| Architecture | Municipal Engineering |
| Boilermaking | Patternmaking |
| Building | Plumbing |
| Chemical Engineering | Radio |
| Civil Engineering | Sanitary Engineering |
| Dairy Farming | Sheet-Metal Work |
| Diesel Engineering | Steam Engineering |
| Draughtsmanship | Structural Engineering |
| Electrical Engineering | Surveying |
| Gas-Power Engineering | Television |
| Horticulture | Textiles |
| Heating and Ventilation | Welding, Gas & Electric |
| Marine Engineering | Woodworking |

EXAMINATIONS, state which.....

NAME.....AGE.....

ADDRESS.....

A Scout from the Past

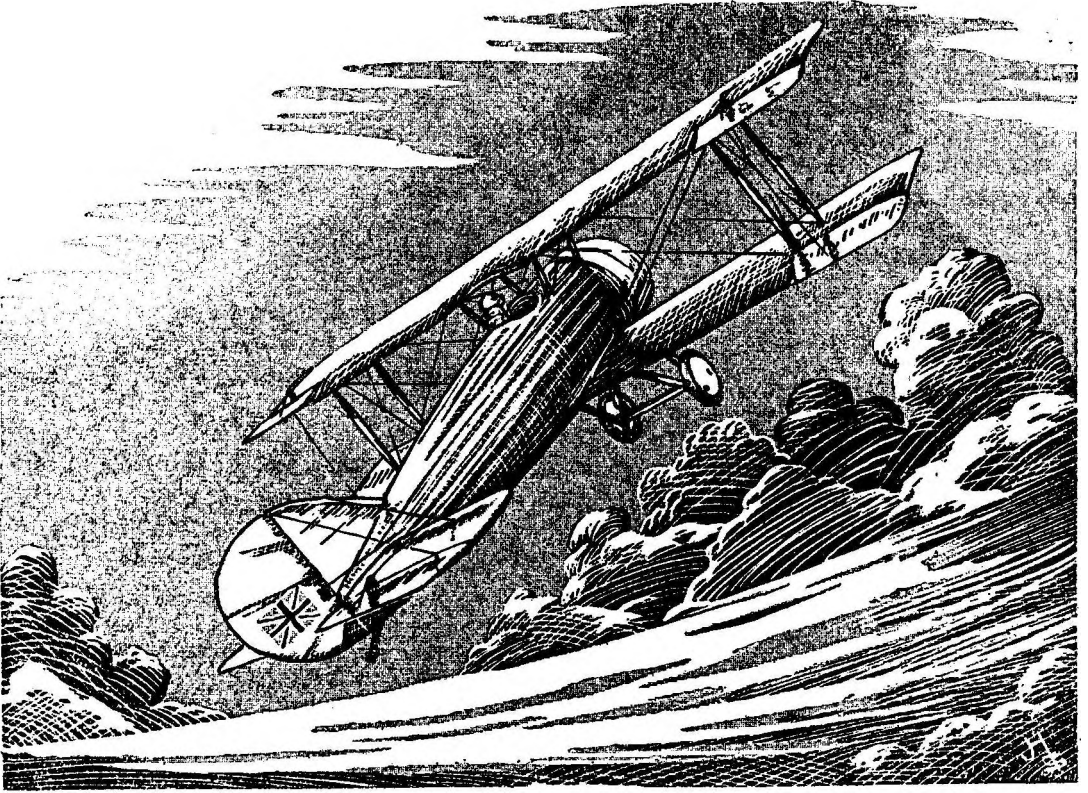

A Description of the Little-known Vickers Bullet, with Full Instructions for Building a Solid Scale Model

By JAMES HAY STEVENS

THE controversy about the Vickers Bullet which has raged for months among readers of AIR STORIES may, or may not, be settled as the result of its adoption as the subject of this month's model-making article. But whether this article finally stills the voice of discord or merely brings fresh arguments to swell it, the following is the writer's story of the Vickers Bullet—and he intends to stick to it!

The Vickers Company built two distinct aeroplanes, both of which were known loosely by the sobriquet "Bullet." In fact, in 1915, any single-seater which was fast was called a "Bullet," as, for example, the Bristol and Morane scouts. The first Vickers Bullet, the Type E.S.1,

was built and flown in August, 1915; the second, the F.B.19, appeared exactly a year later. The original machine was designed by the late Harold Barnwell, who personally did a great deal of work in the construction of the prototype. The designer was in this case accorded the honour (an honour so often denied to designers) of having his name linked with the product of his imagination, and the machine was called the "Barnwell Bullet." The E.S.1 (the initials "E.S." signified Experimental Scout) had a really remarkable performance, but was of no great military value because the synchronised gun had not then been invented, and the pilot's view had been sacrificed to obtain speed.

AIR STORIES

The F.B.19 of 1916 (F.B. standing for Fighting Biplane) retained many of the characteristics of the earlier model. Although essentially similar to the E.S.1, it had a very much improved view, which had been obtained by raising the centre-section and cutting a hole in it like that in the Camel's top plane. The rounded fairing on the sides of the fuselage was not continued aft of the pilot's cockpit, while the bottom of the fuselage was flat. Although not adopted by the R.F.C., several of these aeroplanes were supplied to the Russian Air Service. These few words must suffice for the F.B.19, as this article deals with the earlier machine.

In construction, the E.S.1 was entirely conventional; it was its aerodynamic design which made it outstanding. The wings were of equal span and chord. The Gnome-engined machine had flat planes, but those on the Clerget model were rigged with 1° dihedral.

The fuselage was faired to a circular section right aft to the tail. It was this fairing, together with the diminutive size of the machine, which gave it its good performance.

A rather curious point to note is that there was no windscreen, but it must be remembered that in those pioneer war days pilots were hardy folk and scorned such luxuries.

The long low aspect ratio fin and rudder on the machine were typical of early aeroplane design.

THE E.S.1 was tested both with the 100 h.p. Clerget and the 100 h.p. Gnome Monosoupape engines. The available performance figures for both types are given below, and the figures for the F.B.19 have also been given as a matter of interest. The F.B.19 was fitted with 110 h.p. Le Rhône, though the 100 h.p. Clerget and Gnome were also used.

Performance Comparison of the Vickers Bullet

	E.S.1 Gnome.	E.S.1 Clerget.	F.B.19.
Speed at 5,000 ft. ...	114 m.p.h.	109 m.p.h.	—
Do., 10,000 ft. ...	—	—	102 m.p.h.
Climb to 5,000 ft.	6.66 min.	6.4 min.	5.33 min.
Do. 10,000 ft. ...	18 min.	18 min.	14 min.
Ceiling ...	15,500 ft.	15,500 ft.	17,500 ft.
Landing Speed ...	46 m.p.h.	50 m.p.h.	49 m.p.h.
Weight, empty ...	843 lbs.	921 lbs.	900 lbs.
Weight, loaded ...	1,295 lbs.	1,458 lbs.	1,485 lbs.

HOW TO BUILD THE SCALE MODEL

Materials, Tools and Methods of Construction and Assembly

THE three-view General Arrangement drawings reproduced opposite are drawn to a scale of $\frac{1}{72}$ nd, and the dimensions for materials, given hereafter, are also for a model to this scale. If it is desired to make a model to a different scale it is advisable to re-draw the drawings full size to the scale chosen. The scale of feet on the drawings has been included to assist conversion from $\frac{1}{72}$ nd to any other scale.

Materials and Tools

THE approximate overall dimensions of the materials from which to make the parts of the model are as follows: a block of wood, $3 \times \frac{5}{8} \times \frac{5}{8}$ in. for the fuselage; a piece of wood, $4\frac{1}{2} \times 2 \times \frac{3}{32}$ in. for the main planes; a sheet of fibre $3 \times 2 \times \frac{1}{16}$ in., for the tail unit; 18 in. of 20-gauge brass wire for the various struts; a coil of fine florist's wire for the interplane and other bracing.

A SCOUT FROM THE PAST

THE VICKERS BULLET SINGLE-SEATER SCOUT

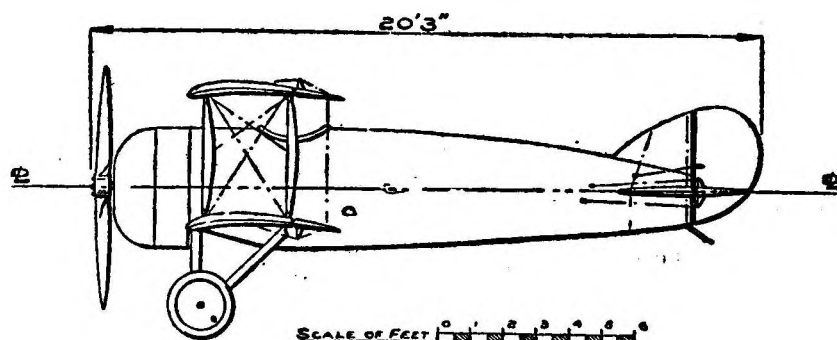

SCALE OF FEET

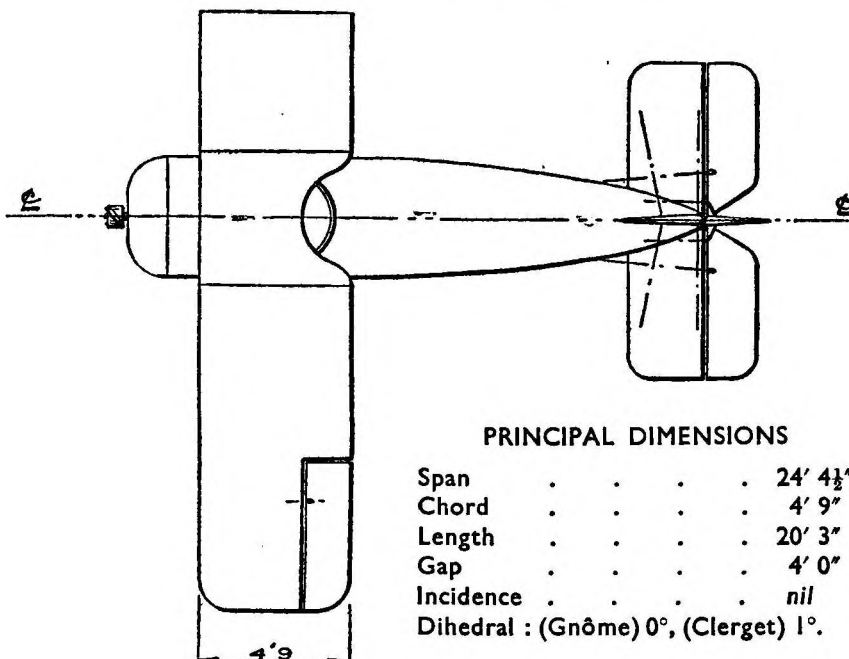

PRINCIPAL DIMENSIONS

Span	24' 4½"
Chord	4' 9"
Length	20' 3"
Gap	4' 0"
Incidence	nil
Dihedral	: (Gnome) 0°, (Clerget) 1°.	

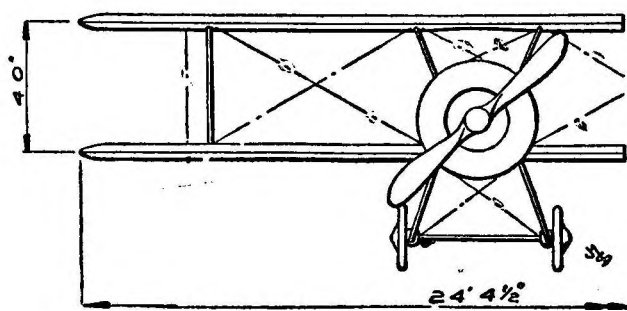

A General Arrangement Drawing drawn to a 1/32nd scale and showing side elevation, plan view and head-on view of the Vickers Bullet single-seater fighter of 1915

AIR STORIES

Wheels and airscrew may be purchased from most model dealers or toy shops, and a turned wooden engine cowling can also be obtained from the same source.

With regard to the choice of wood, American whitewood or beech are the best woods for the fuselage, while any good fretwood (not plywood) will do for the wings—satin walnut or birch are two of the most suitable. No great difficulty should be experienced in obtaining these woods from a local cabinet-maker or from a handicraft shop.

The list below affords a guide as to the essential tools: a $\frac{1}{4}$ -in. chisel; small plane; penknife; oilstone; fretsaw; small half-round file; $\frac{1}{16}$ -in. bradawl; archimedean drill; small long-nosed pliers; tube of cellulose glue; a penny ruler measuring in $\frac{1}{10}$ ths, $\frac{1}{12}$ ths and $\frac{1}{16}$ ths of an inch.

Method of Construction

BEFORE starting work (in fact, even before materials and tools are got together), it is advisable to read these instructions through and make sure that they are clearly grasped.

To begin, trace the side elevation of the fuselage from the G.A. Drawing. Lay the tracing on the fuselage block, pin-prick the outline and line it in with a pencil. Cut away the surplus wood with saw, plane and chisel. Draw a centre-line on the top and bottom surfaces of the wood block, mark in the plan view on the top surface and again remove the surplus wood. Draw the cut-out for the lower

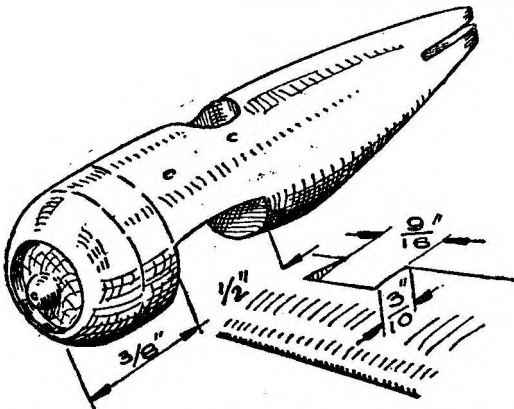

Fig. 1.—The complete fuselage, showing cut-out for the lower plane

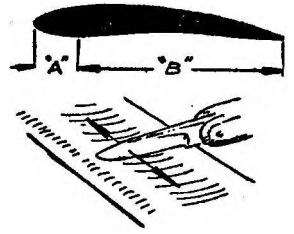

Fig. 2.—Showing camber of the main planes and, below, method of shaping the concave under-surface

plane on the side of the fuselage block—the dimensions of this cut-out are given in Fig. 1. Give the fuselage its correct rounded section; this is circular almost throughout the entire length, except for the vertical knife-edge at the tail. If the engine cowling is being made in one piece with the fuselage (as is shown in Fig. 1), great care should be taken to ensure that it is made absolutely circular. Next, hollow out the cockpit, make the holes for the centre-section struts and tail skid, and cut the slot for the tail-plane.

The first step in the making of the wings is to draw their outline on the piece of wood. Then cut out the wings and camber first the lower and then the upper surfaces. The slightly concave undersurface is obtained by scraping along the span with the blade of a penknife. The concave upper surface is cambered with plane and glasspaper.

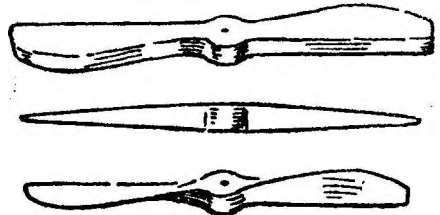

Fig. 3.—Illustrating the three main stages in carving a two-bladed airscrew from a piece of wood

The section of the wing is shown in Fig. 2. Now make the holes for the interplane and centre-section struts.

The tail unit, fin and rudder, and tail-plane and elevator sections are cut from fibre, and are cambered to a very flat symmetrical section with a file and glasspaper.

The various struts and the under-carriage vees are made from brass wire. Fig. 3 shows how to carve the airscrew from a piece of odd wood, while Fig. 4

A SCOUT FROM THE PAST

shows a method for making wheels from linen buttons filled with plastic wood.

Method of Assembly

GLUE the lower plane in place beneath the fuselage. When it has set firmly, fit the wire interplane and centre-section struts and then the upper plane. Adjust for alignment and for correct gap. Glue the end of the struts and put the assembly away until the glue dries.

Glue the tail-plane and rudder units in place, taking care that they are aligned squarely with the wings and also in relation to each other.

Adjust the undercarriage vees, and when they are satisfactory glue them in place. Thread the wheels and axles. Fit the airscrew on a pin—and the model is complete.

Bracing wires are fitted after assembly, and the method given hereafter is the easiest: smooth all the "kinks" out of the wire, and then cut it off to the dead lengths of the various wires on the model. Pick up a wire very carefully with a pair of tweezers (or small long-nosed wireless pliers) and apply a small blob of glue to each end; then carefully put the wire in place on the model. Repeat the operation until all the wires are in place. Where

two wires cross each other they should be glued together with a minute spot of glue. A neat workman will probably find it best to fit the wires after painting.



Fig. 4.—Stages in making a wheel from a linen button

Colour Scheme and Painting

THE entire machine should be painted silver except the struts, which should be coloured the yellowish shade of varnished spruce. The rudder should have a small Union Jack painted on it. The original machine did not have any other markings, but it improves the look of the model to paint it with rings and stripes on the rudder.

The painting materials consist of small 3d. pots of enamel. The best brushes are a No. 5 camel hair or sable, and a small liner's brush. Put the silver on in two or three coats. Each coat should be applied very thinly and evenly. With the wings, at least one coat should be along the grain; the others, and in particular the final one, should be across. On the other hand, the painting of the fuselage should be mainly done along the grain.

NEXT MONTH: The Westland Lysander

HERE'S THE ANSWER

More Replies to Readers' Enquiries

RENÉ FONCK (A. T. Merry, Weston-super-Mare, Som.). Fonck has not yet written his autobiography, but if, and when, he does, the reminiscences of France's leading ace should make thrilling reading.

AIR CASUALTIES (Desmond Cain, Cairo, Egypt). (1) Total casualties of our air services during the Great War are officially given as 8,136 killed, dead or missing, and 7,245 wounded or injured. (2) No reliable figures are available as to the result of all Operations in the Air during the war, but the following official figures apply to the Western Front from July, 1916, and to other fronts in 1918 only: Enemy aircraft accounted for, 8,000; enemy balloons destroyed, 250; British aircraft missing, 3,000; bombs dropped, 8,000 tons; photographs taken, 500,000; rounds fired at ground targets, 12,000,000.

No. 43 SQUADRON (John E. Barnes, Brighton, Sussex). No. 43 (Fighter) Squadron was first formed at Stirling on April 15th, 1916, and all

three of its original flight commanders, A. Lees, J. C. Russell and W. V. Strugnell are still serving in the R.A.F. It went to France in January, 1917, equipped with Sopwith 1½ Strutters, was later re-equipped with Camels and ended the war with Snipes. Its total "bag" was 35 enemy aircraft (including balloons) shot shown in flames, 75 seen to crash and 49 sent down out of control. The squadron lost 53 officers and men killed or missing, 23 wounded, 32 taken prisoners, and 12 killed in accidents. Disbanded at Spittlegate in December, 1919, the squadron was re-formed in July, 1925, and equipped with the Snipes with which it had finished the war. It now flies Hawker Furies and is stationed at Tangmere, Sussex.

HAWKER HORNET (Robert Crossman Toronto, Canada). (1) The Hornet was the original name of the Hawker Fury, and was changed on the aircraft's adoption by the R.A.F. to accord with a new Air Ministry system of nomenclature. In its latest form, with a special Rolls-Royce Kestrel engine and semi-evaporative cooling, it has a top speed of 250 m.p.h. at 12,300 ft. The top speed of the Siskin 3a, with a 425 h.p. Jaguar engine, was 153 m.p.h. at 10,000 ft. (2) You should know more than we do about the aircraft types used in the R.C.A.F. Why not write to R.C.A.F. Headquarters, c/o National Defence H.Q., Ottawa?

3 Books by "Air Stories" Authors

ACE OF THE BLACK CROSS

by
Ernst Udet

This book is at once a record of almost incredible adventure and the chronicle of a grim period in world history which may never have an equal. Ernst Udet was sent to the front for his country in 1914 as a motor-cycle dispatch rider. He soon, however, graduated to the Imperial Air Force, where his brilliant aerobatics singled him out. He became a lone wolf, rushing down on Allied aircraft out of the blue and scoring successes almost unequalled in the war in the air. He was responsible in all for 62 Allied aircraft and 100 English and French aviators. Udet's book is an important contribution to the literature of the world war, in addition to being a brilliant and thrilling tale of adventure. English readers will not fail to appreciate this frank account of an enemy's campaign.

6/- net, 6/6 post free

STEELEY FLIES AGAIN

by
Capt. W. E. Johns

Steeley Delaroy, who made his bow in "Sky High," returns in this new thriller-of-the-air.

"A twentieth-century Robin Hood with the sky for Sherwood and police officers for sheriffs to outwit."—*News Chronicle*.

3/6 net, 3/9 post free

THE THREE SQUADRONS

by
Wilfred Tremellin

Wilfred Tremellin's powers of telling a thrilling tale in the most graphic language are well known to readers of "Air Stories." The adventures of the three squadrons in the war will keep every air-minded man enthralled from the first page to the last.

3/6 net, 3/9 post free

From all Booksellers

or at post free rates from: Book Dept., Tower
House, Southampton Street, Strand, London, W.C.2

NEWNES :: LONDON

CONTACT *by the* EDITOR

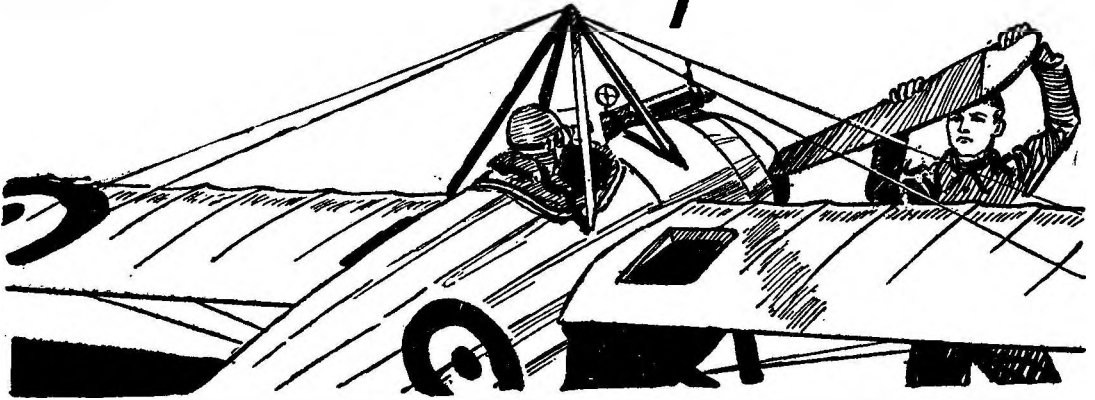

Editorial Offices: Tower House, Southampton Street, Strand, London, W.C.2

MAJOR L. S. METFORD, who contributes the fine story "Early Birdmen" to this issue, is well qualified to write of the early days of aviation, for not only did he learn to fly in the "heroic" days of 1911, but he was also one of the first members to join the Flying Corps on its inception in 1912.

His modesty has hitherto prevented us from recognising him as the most senior of the many air-war veterans who now write for AIR STORIES, but we have at last been able to extract from him a brief account of his distinguished service record, which will be of interest to his many admirers among our readers.

Major Metford first learnt to fly at Hendon in the summer of 1911 when that now famous aerodrome was nothing more than a few rough fields "on the edge of beyond." He got his pilot's ticket on a 35-h.p. three-cylinder Anzani-engined Blériot and celebrated the event with two fellow-pupils who had also won their wings on that day. One of these was W. B. Rhodes Moorehouse, destined to become the first Flying Corps V.C.; the other was Zee Yee Lee, the first Chinaman to learn to fly.

The following year saw the formation of the Flying Corps—it had not then been honoured with the "Royal" prefix—and Metford was one of the first officers

to be enrolled in the new force. In 1913 he was posted to the Central Flying School at Upavon. The adjutant there was a resonant-voiced officer named Hugh Trenchard—later to become Commander of the R.F.C. in France and, to-day, Lord Trenchard, Marshal of the Royal Air Force.

Metford was on home leave in Canada when the War broke out, but by catching the first boat from Montreal he managed to join his unit in France before the end of August, 1914.

What the War Office Said in 1915

HIS four years of war service with the R.F.C. and R.A.F. Major Metford dismisses as "so precisely similar to the experiences of scores of others as to be really not worth mentioning," though he does admit that the plots of most of his yarns in AIR STORIES are largely based on adventures that befell him during the War. He also confesses to having been seriously wounded several times, and to have invented a number of gadgets including a four-way inclinometer and a bomb-sight. He even tried to interest the War Office in parachutes in 1915, but was told that such things would never be used in the R.F.C. His chief claim to fame, however, he insists, is that he was never shot down by Richthofen—a distinction almost as unique as that of the American pilot

AIR STORIES

who admitted he had never been a member of the Lafayette Escadrille.

After the War, Major Metford returned to Canada and served with the Canadian Air Force until the economy "axe" descended and, like so many other famous Canadian war fliers, he was posted to the Reserve with an occasional short refresher course at Camp Borden. "But now," he writes, "what with war scares and so forth, things are looking up very considerably in the Dominion, so I expect very shortly to be in harness again. At least, I hope so."

From which one gathers that, after twenty-six years' flying experience, Major Metford's enthusiasm for the game is still as keen as ever it was. Obviously, there is no keeping a regular warbird out of the air—particularly if he happens to be an early Canadian "birdman" ("Ugh—terrible!").

Brickbat Department

FROM an anonymous reader in Cambridge who signs himself "Safety First," comes the following solicitous communication:

"I notice with grave concern that the gentleman swinging the prop. in the sketch that heads 'Contact' is endeavouring to do so backwards. As I presume from the heading that the order has been 'Contact' and not 'Switches off, throttle open, suck in,' I fear the consequences may be serious. Wishing your entertaining magazine all success."

We decline either to have our leg pulled or to admit defeat. The engine in the aircraft depicted in the sketch is fitted with a right-handed or clockwise-rotating engine—and we defy our ironical critic from Cambridge to disprove it!

That 330 m.p.h. Fighter

THE mystery of the French fighter which, when it appeared in a recent news-reel, was credited by the commentator with a speed of 330 m.p.h. is not yet, it seems, solved.

"I think," writes Mr. G. N. Stear of Highgate, London, "that your correspondent, Mr. McClure, was mistaken in identifying the French machine in the news-reel as a Caudron Rafale. I saw the picture in question and I think the machine was the Mureaux 190 fighter, equipped with a Salmson inverted vee-twelve cannon engine and an addi-

tional armament of two machine-guns. It was exhibited in the recent Paris Aero Show. The general lay-out of the two machines is very similar, so that a mistake is excusable."

There still remains, however, the mystery of the alleged 330 m.p.h., as with an engine of only 450 h.p. and such a weight of armament, it seems improbable that the Mureaux could rival the speed of our latest fighters with their far more powerful engines.

No "Dirty Dogs" Here

A WELCOME letter in which praise and constructive criticism are nicely blended comes from Mr. R. P. Trebell of Brockley, S.E.4, who writes:

"Just a few lines of appreciation for a year full of good stories from a very well satisfied reader. I would specially like to compliment you on 'Winged Warriors' and 'Aerial Enemy No. 1,' also 'The Penalty is Death.' One of the things that I like about the War stories featured is that there is an almost total absence of the 'Dirty Dog' and 'Low down swine' attitude towards German pilots. It is probable that we, the children of the post-war generation, are realising that the average German is every bit as good as we are, and any attempt to try and foster a feeling of hate towards them is foolish and futile.

"Could we have a little less of the spectacular, which I notice is creeping in, and more stories on the lines of 'Winged Warriors'—the real, humdrum, yet fast-moving life of an R.A.F. pilot at war? I would also like to see one or two stories dealing with the Fleet Air Arm.

"The Model Section, too, deserves high praise, though the 'planes most mentioned in AIR STORIES, such as the Camel, S.E.5, Fokker D.R.1, Fokker D.7 and R.E.8, are conspicuous by their absence. Why is this? Meanwhile, I am all for the Model Section being kept going.

"My only real complaint, however, is that AIR STORIES does not come out every week, or at least fortnightly."

Another fine real-life story in the tradition of "Winged Warriors" will shortly be starting in AIR STORIES. We recently published a Fleet Air Arm yarn, and its author, who is a specialist in this branch of R.A.F. activity, has promised us another in the near future. As regards the Model Section, we have purposely avoided such well-known aircraft as those mentioned, believing that most model enthusiasts have long since built them and prefer us to feature the lesser known types of Great War 'planes about which data is difficult to obtain. If we are wrong, write and tell us so.



SIGHT SAVER

TO THE LOVER
AND THE POET

THE EYE
IS THE WINDOW OF THE SOUL'

but to most of us **Good Eyesight** is the first essential for gaining a livelihood. Good Eyes in a man or woman command attention. Near sight, far sight, astigmatism and **Tired Eyes** are a handicap in business and social intercourse.

ARE YOU BEING FAIR TO YOURSELF? Nature warns us of eyestrain by unmistakable signs—a blurred vision, a headache, "spots" or a sense of Eye Weariness.

DO NOT NEGLECT NATURE'S SIGNALS There is generally no need for spectacles, operations, or medicine. You can stimulate your sight and improve the **Look of Your Eyes** by a simple system of manipulation which you can practise in your own home. This new scientific

MESSAGE FOR THE EYE

is a real Sight Saver and explained in a Shilling Book which we are prepared to send **FREE** to sufferers from Eye-Defects, asking only for 6d. (stamps) to cover postage.

DELAYS ARE DANGEROUS

Send NOW to

NEU-VITA (Dept. J.U.)

177-252 Central Buildings, London
Bridge, London, S.E.1, England



AEROMODELS

¹/₂₄th FULL SIZE (NON FLYING) CONSTRUCTION KITS

S.E. 5A
Wing
Span
134 ins

COMPER "SWIFT" PRICE 3/6	NOW 2/6
D.H. "FOX MOTH" PRICE 4/-	NOW 3/-
S.E. 5A PRICE 3/6	NOW 3/-
HAWKER "HART" PRICE 5/-	NOW 4/-
SOPWITH "CAMEL" PRICE 4/-	NOW 3/-
BRISTOL "BULLDOG" PRICE 6/-	NOW 4/6
GLOSTER "GAUNTLET" PRICE 5/-	NOW 4/-
D.H. "DRAGON" PRICE 7/6	NOW 5/6

FREE PLEASE SEND ME ILLUSTRATED LITERATURE CONTAINING FULL DETAILS OF ALL AEROMINOR KITS. 3d. Stamp is sufficient if envelope is unsealed.

NAME.....
ADDRESS.....

AEROMODELS LTD.

DEPT. B. No. 5, 1st FLOOR, WELLINGTON BLDGS., LIVERPOOL 2

BRITISH LABOUR

EMPIRE MATERIAL

SCALE MODELS

EVERY kind of accessory required by the 1/24th Scale Modeller. "Mercury" Motors, Cowling Rings, Wheels, Spats, Airscrews, Guns, Letter and Cockade Transfers, Cockpit Figures, Pilots, Mechanics, Petrol Tenders, etc.

SKYBIRD LEAGUE H.Q. DESKAS.

3, Aldermanbury Ave., London, E.C.2.

Engineers' Guide

For a well-paid post study at home with The T.I.G.B. Write NOW for this great Guide containing world's widest choice of engineering courses—covering all branches—and which alone gives the Regulations for Qualifications, such as A.F.R.Ae.S., A.M.I.Ae.E., A.M.I.Mech.E., A.M.I.E.E., etc. Successful Training Guaranteed.

The Technological Institute,
125 Temple Bar House,
London, E.C.4

(Founded 1917. 20,000 Successes)

Free!

200 Courses

To Success

THE WEBLEY SERVICE AIR RIFLE No. II

NO LICENSE REQUIRED TO PURCHASE
WRITE FOR DESCRIPTIVE FOLDER

Rocks, Rabbits, Rat, Sparrow and similar vermin can be destroyed by it in extremely accurate and powerful Air Rifle Ideal for Target Practice.

CALIBRE .22 or .177 WITH Light and Powerful WEBLEY & SCOTT Ltd. 101 WEAMAN St. BIRMINGHAM 4

WANTED.

Numbers 1, 3, 4 and 7 of "Air Stories," Vol. 1. Will any reader who is willing to dispose of these issues write, giving price required, condition, etc., to Box 12, "Air Stories," George Newnes Ltd., 8-11 Southampton St., Strand, London, W.C.2?

1/24th. SOLID SCALE MODEL KITS!!

Megow's (U.S.A.). 8" span. Complete. Postage, 2½d. Aeronca LW, Consolidated P3Y-1, Fiat CR-30, Fokker D7, Albatross, Curtiss Condor, Bristol Fighter, Curtiss Coupe, Hell Diver, Cessna C34, Douglas Transport, Kinner Envoy, China Clipper, Fairchild Amphibian, Luscombe Phantom, Macchi-Castoldi, Martin Bomber, Autogiro, Stinson R, Mr. Mulligan, Ryan ST, Stinson U, Northrop Fighter, Seversky BT-8, Taylor Cub, Pfalz D111, Sikorsky S-43, Vought SBU-1, Camel, Vultee Attack.

12" span Solids, 2/6 complete. Mail orders, add 3d. China Clipper, Martin Bomber, Consolidated P30, Lockheed Electra, Douglas Transport, DH Comet.

Don't forget the A.B.C.'s of Model Building, 6d. post free.

AER-O-KITS (Sheffield). Wholesale Distributors for Megow's of Philadelphia and Duncan Gold Seal Kits, Chicago.

All our lines obtainable from **HOBBIES LTD.** and Dealers everywhere.

ALL ADVERTISEMENTS FOR "AIR STORIES" should be addressed to Advertisement Department, George Newnes Ltd., Tower House Southampton Street, Strand, London, W.C.2. Telephone: Temple Bar 4363.

FREE!

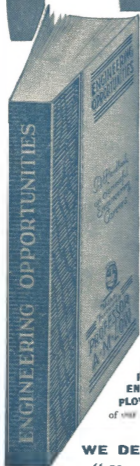

This IMPORTANT GUIDE to SUCCESSFUL ENGINEERING CAREERS

After months of intensive effort and research we are pleased to announce that the 1937 edition of our Handbook, "ENGINEERING OPPORTUNITIES," is now out of the publishers' hands and ready for free distribution.

Containing 268 pages of practical guidance, this book is, beyond argument, the finest and most complete handbook on Successful Engineering Careers ever compiled. It is a book that should be on the bookshelf of every person interested in Engineering whatever his age, position or experience.

The Handbook contains, among other intensely interesting matter, details of B.Sc., A.M.I.C.E., A.M.I.Mech.E., A.M.I.E.E., A.M.I.A.E., A.M.I.W.T., A.M.I.R.E., CIVIL SERVICE and other important Engineering Examinations; outlines courses in all branches of CIVIL, MECHANICAL, ELECTRICAL, AUTOMOBILE, RADIO, TELEVISION and AERONAUTICAL ENGINEERING, BUILDING, GOVERNMENT EMPLOYMENT, etc., and explains the unique advantages of our Employment Department



WE DEFINITELY GUARANTEE

"NO PASS—NO FEE"

If you are earning less than £10 per week you cannot afford to miss reading "ENGINEERING OPPORTUNITIES." In your own interests we advise you to send for your copy of this enlightening guide to well-paid posts, by filling in and posting the coupon NOW. There is no cost or obligation of any kind.

**BRITISH INSTITUTE OF
ENGINEERING TECHNOLOGY**

114a SHAKESPEARE HOUSE,
17, 18 & 19 STRATFORD PLACE, LONDON, W.1

FREE COUPON

BRITISH INSTITUTE OF
ENGINEERING TECHNOLOGY,
114a Shakespeare House, 17-19 Stratford
Place, W.1.

Please forward Free of cost or obligation
of any kind, your 268-page Handbook,
"ENGINEERING OPPORTUNITIES."

NAME _____

ADDRESS _____